

# ProMaster

## Upfit Guide

---



**WORK VEHICLES  
THAT WORK BETTER!**

**advantage**  
**OUTFITTERS**

## What's the Advantage?



### We make it Easy

- Simplified layout and design process
- Technical support and configuration assistance

### We make it Fast

- Everything in this catalog is in stock
- Installs within 48 hours or less

### We make it Last

- Certified and trained Installers
- Lifetime Installation Warranty

## A simple 6 step process to an efficient work van

01. Start with **Interior Finishing**
02. Add a **Safety Partition**
03. Choose your **Shelving Package**
04. Add time-saving **Interior Accessories**
05. Select your **Roof Equipment**
06. Finish with **Exterior Accessories**

Advantage Outfitters is a commercial vehicle upfitter, specializing in storage equipment and accessories for cargo vans. With 20+ years of experience, we have earned the trust of contractors, trade fleets, utilities, municipalities, vehicle dealers, and leasing companies. We are defined by our strong team spirit and our passion for making work vehicles work better.



## Contents

<b>Interior Finishing</b>	<b>04 - 07</b>	<b>Interior Accessories</b>	<b>19-25</b>
Wall Liners	04	Side-Door Drawer Systems	19
Flooring	05	Parts Keepers	20-21
Lashing / Seat Covers / Window Grills	06	Drawer Cabinets	22
Interior Lighting	07	Shelving Accessories	23
<b>Safety Partitions</b>	<b>08 - 09</b>	Cab Accessories	24
Straight Partitions	08	Bottle Holders	25
Contoured Partitions	09	<b>Roof Equipment</b>	<b>26 - 29</b>
<b>Shelving Packages</b>	<b>12 - 17</b>	Side Dropdown	26
Base	12	Rear Dropdown	27
General Service	13	Roof Decks and Cargo Racks	28
HVAC	14	Ladder Rack Accessories	29
Electrical	15	<b>Exterior Accessories</b>	<b>30 - 31</b>
Plumbing	16	Running Boards / Rear Steps	30
Delivery	17	Hitches / Windows / Locks	31
		<b>Specialty Equipment</b>	<b>32-35</b>
		Climate Control	32
		Inverters	33
		Liftgates	34
		<b>Vehicle Layouts</b>	<b>35</b>



sales@advantageoutfitters.com

866.925.4844

advantageoutfitters.com

## VanLiner Wall and Door Protection

- Protect your vehicle investment
- 3/16" light grey plastic with textured finish
- Highly durable & impact resistant



Model	Wall Liners Part#	Door Panels Part#	Model	Wall Liners Part#	Door Panels Part#
118" WB Low Roof	601D2WL	601D2DP	159" WB High Roof	601D5WL	601D4DP
136" WB Low Roof	601D3WL	601D3DP	159" WB Ext High Roof	601D6WL	601D4DP
136" WB High Roof	601D4WL	601D4DP	159" WB Ext Super High Roof	601D7WL	601D4DP

## Duratherm Insulated Kits

- 3/8" Heavy duty rigid grey plastic wall protection with 1/8" foil/foam insulation layer
- Provides sound deadening and an R4 equivalent thermal barrier
- Textured surface is scratch and impact resistant



Model	Wall Liners Part#	Door Panels Part#	Ceiling Panels Part#
118" WB Low Roof	654D2WL	654D2DP	654D2CL
136" WB Low Roof	654D3WL	654D3DP	654D3CL
136" WB High Roof	654D4WL	654D4DP	654D4CL
159" WB High Roof	654D5WL	654D4DP	654D5CL
159" WB Ext High Roof	654D6WL	654D4DP	654D6CL
159" WB Ext Super High Roof	654D7WL	654D5DP	654D7CL

## Floor Protection

### Rubber Mat

- 1/4" virgin rubber resists oils and chemicals
- Saves knees and increases traction
- One piece seamless



Model	Rubber Mat Part#
118" WB	654D2RM
136" WB	654D3RM
159" WB	654D5RM
159" WB Ext	654D6RM

### StabiliGrip Floor

- 1/2" hard plastic with fiberglass reinforcement
- Provides firm base for tools and equipment
- Durable, non-skid surface



Model	StabiliGrip Floor Part#
118" WB	654D2SG
136" WB	654D3SG
159" WB	654D5SG
159" WB Ext	654D6SG

### Door Sills

- Custom fit, heavy-duty diamond plate aluminum sill plates
- Protects entry points and provides traction

Description	Door Sill Part#
Set of 2 for Sliding Door and Rear Doors	654DXRSS

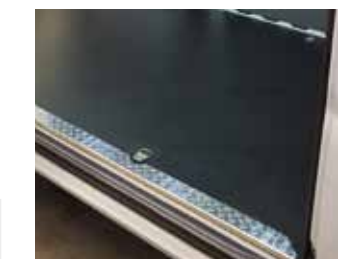

Side Door Sill



Rear Door Sill

### Wheel Well Covers

- Decreases road noise and provides a thermal barrier.
- Does not fit 118" ProMasters

Description	Part#
Wheel Cover	854DXWWC



INTERIOR FINISHING

INTERIOR FINISHING

## Aluminum Lashing Rail

- Durable & versatile
- Single level kits come with 5 movable tie-down rings
- Double level kits come with 10 movable tie-down rings
- Ratchet straps also available



Model	Single Level Part#	Double Level Part#
118" WB LR	842D2LK	—
136" WB LR	842D3LK	—
136" WB HR	842D3LK	842D4LK2
159" WB HR	842D5LK	842D5LK2
159" WB Ext HR	842D6LK	842D6LK2
8' Ratchet Strap	842XX8RB	842XX8RB
6' Cam Buckle Strap	842XX6CB	842XX6CB



## Seat Covers

- Custom-fit
- Tough Cordura fabric



## Window Grills

- Black painted wire mesh construction

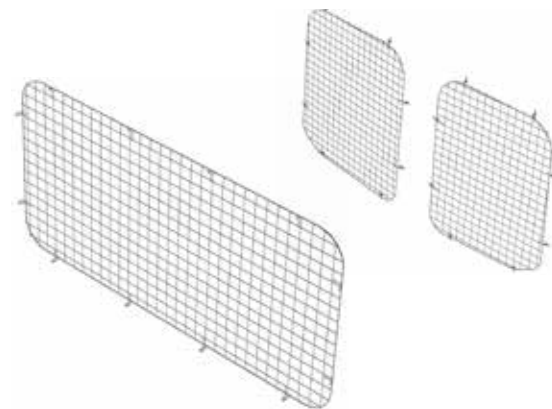

Description	Part#
Seat Covers (set of 2)	876DXSC

Description	Part#
Side Sliding Door	876DXSG
Rear Doors (set of 2)	876DXRG

## Strip Lighting

- High intensity 2' LED light
- Mounts to side of ceiling ribs to maintain headroom'
- Light is not compatible with ceiling liners
- Wired with OEM (door) switch
- 2 recommended for 118" and 136" WB vans
- 3 recommended for 159 and 159 EXT WB vans



Description	Part#
Single 2' LED light	452XXLD2

## Motion Sensor Lighting



- Motion sensor activated
- Recommended for install with Duratherm ceilings
- 2 recommended for 118" and 136" WB vans
- 3 recommended for 159 and 159 EXT WB vans

Description	Part#
1 LED light	454XXLK1
2 LED light	454XXLK2
3 LED light	454XXLK3
Bracket and hardware	454XXBH*

\* Required for vans without ceiling

## Our 6 Step Process

Start with **Interior Finishing** 01

Add **Safety and Security** 02

Choose your **Shelving Package** 03

Add time-saving **Interior Accessories** 04

Select your **Roof Equipment** 05

Finish with **Exterior Accessories** 06

## Partitions Without Door

### Pass Through

- Galvanized steel
- 5" setback for seatback travel
- Drivers side and passenger panels only

### Full Partition

- Galvanized steel
- 5" setback for seatback travel
- Includes a Mesh upper for visibility into rear
- Includes center panel



Pass through partition

Full partition

Available with or without center panel.

Description	Part#
Pass Through Partition	276DXPTP
Full Partition	276DXSP

## Partitions With Door

### Swing Door Partition

- Galvanized steel
- Hinged door with latch
- 5" setback for seatback travel
- Mesh upper for visibility into rear
- Versatile & economical

### Sliding Door Partition

- Lightweight & durable aluminum
- Lockable sliding door
- Polycarbonate Window for visibility into rear
- Rattle free design



Swing Door Partition

Sliding Door Partition

Description	Part#
Swing Door Partition	276DXHDP
Sliding Door Partition	176DXSDP

## Contoured Composite Partitions

- Designed for maximum impact resistance
- Thermally stable in any weather condition
- Perfect fit regulates heating and cooling in the cab
- Keeps dust and smells in the rear from getting into the cab



Solid Composite

Composite with Window

Description	Part#
Solid Composite	276DXPTP
Composite With Window	176DXP-CW

## Contoured Aluminum Partition

- Lightweight & durable aluminum
- 10' clear at floor in a 136" WB.
- Available with or without polycarbonate window.



Contoured Solid Partition

Contoured Partition - Window

Description	Part#
Contoured Solid Composite	176DXCP
Contoured Composite With Window	176DXWP

SAFETY PARTITIONS

SAFETY PARTITIONS

# Increase your productivity with our Trade-Specific Packages



## What's our Shelving Advantage?

### Durable



Load tested to **1200 lbs** per shelf

### Secure

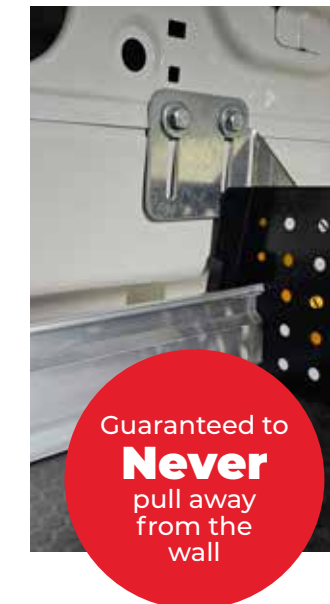

Guaranteed to **Never** pull away from the wall

### Lightweight



Save **FUEL** and increase **Payload** capacity

### Quiet

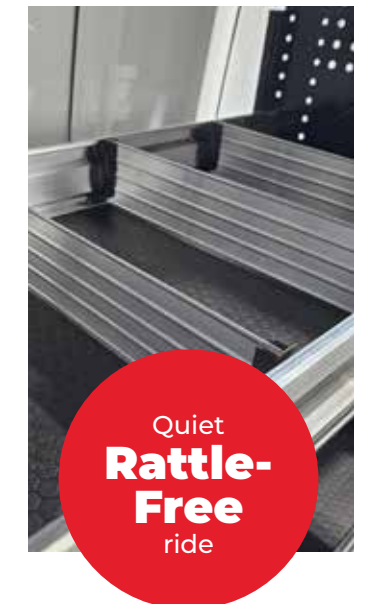

Quiet **Rattle-Free** ride

## Here's what our customers say about their outfitted vans

"My technicians are able to keep the vans organized, which increases our overall efficiency."

Mike S.  
HVAC Service Company.



"You really helped us get the maximum benefit out of our vehicles."

Michael R.  
Fire Protection Company.



## Our 6 Step Process

- |   |                               |  |
|---|-------------------------------|--|
| Start with Interior Finishing 01        | Add Safety and Security 02    | <b>Choose your Shelving Package 03</b> |
| Add time-saving Interior Accessories 04 | Select your Roof Equipment 05 | Finish with Exterior Accessories 06    |

## Base Package – 136" WB

**Driver's side includes:**

- (1) 62"H x 84"L 4-shelf shelving unit

**Passenger's side includes:**

- (1) 62"H x 48"L 4-shelf shelving unit



Partitions And Flooring Are Not Included In Shelving Packages

Description	Part#
Base Package, 136" WB	276D3BP

## General Service Package – 136" WB

**Driver's side includes:**

- (1) 62"H x 84"L 4-shelf shelving unit
- (10) adjustable 3" rattle-free dividers
- (2) 18.5"W x 10.5"H 2-drawer cabinets
- (1) fixed hook

**Passenger's side includes:**

- (1) 62"H x 48"L 4-shelf shelving unit
- (4) 14"D x 12"W plastic bins
- (1) swivel hook



Partitions And Flooring Are Not Included In Shelving Packages

Description	Part#
General Service Package, 136" WB	276D3GSP

## Base Package – 159" WB

**Driver's side includes:**

- (1) 62"H x 96"L 4-shelf shelving unit

**Passenger's side includes:**

- (1) 62"H x 60"L 4-shelf shelving unit



Partitions And Flooring Are Not Included In Shelving Packages

Description	Part#
Base Package, 159" WB	276D5BP

**Also Available for 118" WB**

Base Package Part# 276D2BP

## General Service Package – 159" WB

**Driver's side includes:**

- (1) 62"H x 96"L 4-shelf shelving unit
- (10) adjustable 3" rattle-free dividers
- (2) 18.5"W x 10.5"H 2-drawer cabinets
- (1) fixed hook

**Passenger's side includes:**

- (1) 62"H x 60"L 4-shelf shelving unit
- (4) 14"D x 12"W plastic bins
- (1) swivel hook



Partitions And Flooring Are Not Included In Shelving Packages

Description	Part#
General Service Package, 159" WB	276D5GSP

**Also Available for 118" WB**

General Service Package Part# 276D2GSP

## HVAC Package – 136" WB

### Driver's side includes:

- (1) 62"H x 84"L 4-shelf shelving unit
- (7) 14"D x 12"W plastic bins
- (2) 18.5"W x 10.5"H 2-drawer cabinets
- (1) large gas bottle holder
- (1) fixed hook

### Passenger's side includes:

- (1) 62"H x 48"L 4-shelf shelving unit
- (10) adjustable 3" rattle-free dividers
- (1) 43" H by 13.5" W 3-tier refrigerant rack for bottles
- (1) swivel hook

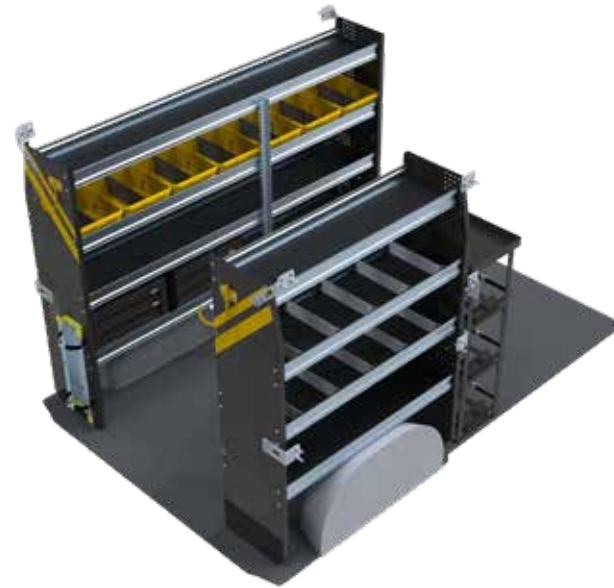

Partitions And Flooring Are Not Included In Shelving Packages

Description	Part#
HVAC Package, 136" WB	276D3HP

## Electrical Package – 136" WB

### Driver's side includes:

- (1) 62"H x 84"L 4-shelf shelving unit
- (7) 14"D x 12"W plastic bins
- (1) 11"H x 48"L locking cabinet
- (1) 11"H x 36"L locking cabinet
- (1) 18.5"W x 10.5"H 2-drawer cabinet
- (1) 18.5"W x 10.5"H 3-drawer cabinet
- (1) wire reel holder
- (1) fixed hook

### Passenger's side includes:

- (1) 62"H x 48"L 4-shelf shelving unit
- (10) adjustable 3" rattle-free dividers
- (1) swivel hook



Partitions And Flooring Are Not Included In Shelving Packages

Description	Part#
Electrical Package, 136" WB	276D3EP

## HVAC Package – 159" WB

### Driver's side includes:

- (1) 62"H x 96"L 4-shelf shelving unit
- (7) 14"D x 12"W plastic bins
- (2) 18.5"W x 10.5"H 2-drawer cabinets
- (1) large gas bottle holder
- (1) fixed hook

### Passenger's side includes:

- (1) 62"H x 60"L 4-shelf shelving unit
- (10) adjustable 3" rattle-free dividers
- (1) 43"H x 10.5"W 4-tier refrigerant rack for bottles
- (1) 11"H x 60"L locking cabinet
- (1) swivel hook

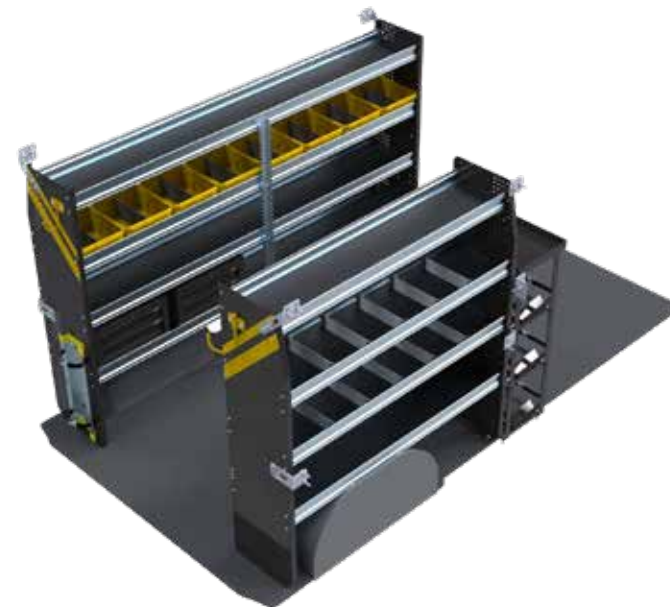

Partitions And Flooring Are Not Included In Shelving Packages

Also Available for 118" WB  
HVAC Package Part# 276D2HP

Description	Part#
HVAC Package, 159" WB	276D5HP

## Electrical Package – 159" WB

### Driver's side includes:

- (1) 62"H x 96"L 4-shelf shelving unit
- (7) 14"D x 12"W plastic bins
- (1) 11"H x 48"L locking cabinet
- (1) 18.5"W x 10.5"H 2-drawer cabinet
- (1) 18.5"W x 10.5"H 3-drawer cabinet
- (1) wire reel holder
- (1) fixed hook

### Passenger's side includes:

- (1) 62"H x 60"L 4-shelf shelving unit
- (10) adjustable 3" rattle-free dividers
- (1) swivel hook



Partitions And Flooring Are Not Included In Shelving Packages

Also Available for 118" WB  
Electrical Package Part# 276D2EP

Description	Part#
Electrical Package, 159" WB	276D5EP



## Plumbing Package – 136" WB

### Driver's side includes:

- (1) 62"H x 84"L 4-shelf shelving unit
- (10) adjustable 3" rattle-free dividers
- (1) 18.5"W x 10.5"H 2-drawer cabinet
- (1) 18.5"W x 10.5"H 3-drawer cabinet
- (1) large gas bottle holder
- (1) fixed hook

### Passenger's side includes:

- (1) 62"H x 48"L 5-shelf shelving unit
- (16) 14"D x 12"W plastic bins
- (16) cross dividers for plastic bins
- (1) large gas bottle holder
- (1) swivel hook

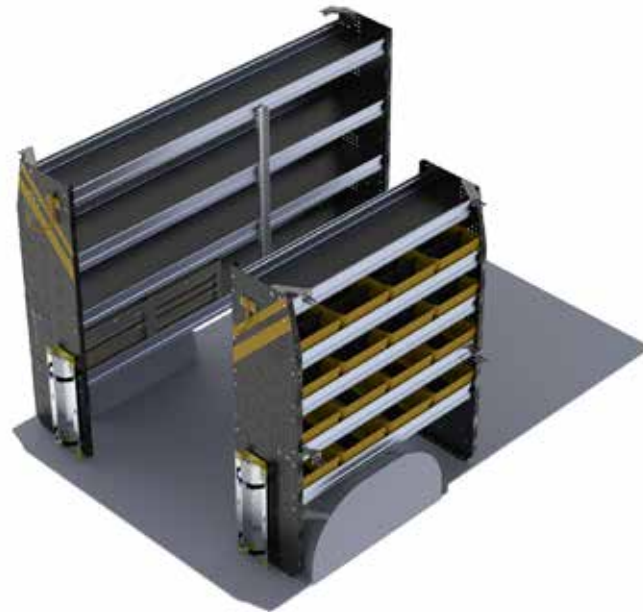

Partitions And Flooring Are Not Included In Shelving Packages

Description	Part#
Plumbing Package, 136" WB	276D3PP

## Plumbing Package – 159" WB

### Driver's side includes:

- (1) 62"H x 96"L 4-shelf shelving unit
- (10) adjustable 3" rattle-free dividers
- (1) 18.5"W x 10.5"H 2-drawer cabinet
- (1) 18.5"W x 10.5"H 3-drawer cabinet
- (1) large gas bottle holder
- (1) fixed hook

### Passenger's side includes:

- (1) 62"H x 60"L 5-shelf shelving unit
- (20) 14"D x 12"W plastic bins
- (20) cross dividers for plastic bins
- (1) large gas bottle holder
- (1) swivel hook

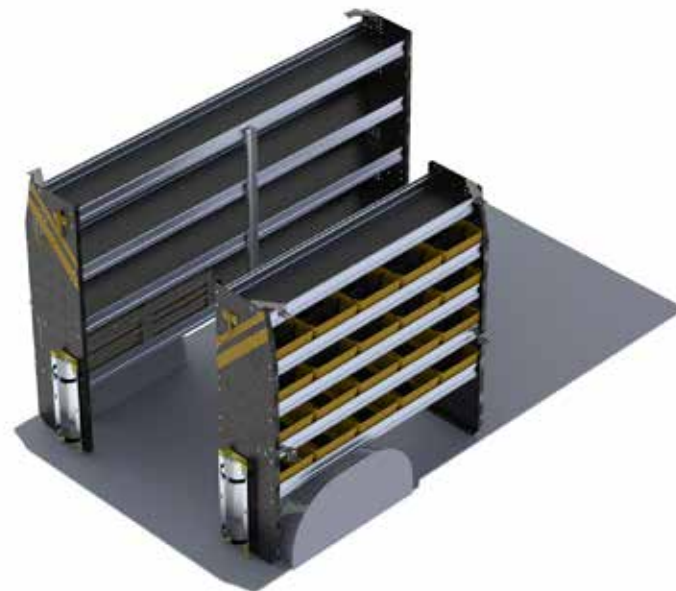

Partitions And Flooring Are Not Included In Shelving Packages

Description	Part#
Plumbing Package, 159" WB	276D5PP

## Delivery Package – 118" WB/136" WB

### Driver's side includes:

- (1) 63"H x 72"L 2-shelf unit with folding shelves

### Passenger's side includes:

- (1) 63"H x 48"L 2-shelf unit with folding shelves



Description	Part#
Delivery Package, 118" WB and 136" WB	176D3DP

## Delivery Package – 159" WB

### Driver's side includes:

- (1) 63"H x 60"L 2-shelf unit with folding shelves
- (1) 63"H x 48"L 2-shelf unit with folding shelves

### Passenger's side includes:

- (1) 63"H x 48"L 2-shelf unit with folding shelves



Description	Part#
Delivery Package, 159" WB	176D5DP

- Folding shelves keep aisle clear when not in use
- Gas shock holds shelf in either up or down position – no latches or rattles
- Capacity is 250 lbs per shelving unit
- Shelves are 20" deep

**DO YOU HAVE  
A FLEET OF  
10+ VANS?**

**Contact us to learn about  
our fleet upfit solutions**



## Organized Time Saver

Access your most common items without even entering your vehicle.



### Build a drawer system that works best for you

01. Start with a **Tool Drawer** for power tools and bags
02. Add **Parts Drawers** for hand tools and components
03. Finish with a **Top Tray** and crates or a **Worktop** surface

## Our 6 Step Process

Start with Interior Finishing 01	Add Safety and Security 02	Choose your Shelving Package 03
Add time-saving Interior Accessories 04	Select your Roof Equipment 05	Finish with Exterior Accessories 06

### Standard Tool Drawer

- Aluminum
- Weight capacity: 320 lbs.
- Open interior for tool bags & cases
- Dimensions: 14"W x 48"L x 16"
- Lockable



Description	Part#
Jumbo Tool Drawer	176XXJTD

### Jumbo Tool Drawer

- Aluminum
- 320 lb capacity
- Open interior for tool bags & cases
- 16"W x 48"L x 20"H
- Lockable



Description	Part#
Jumbo Tool Drawer	176XXJTD

### Parts Drawer

- Aluminum
- 150 lb capacity
- Dividers for parts and hand tools
- Stack 1, 2 or 3 above your jumbo tool drawer
- 12"W x 48"L x 6"H
- Lockable

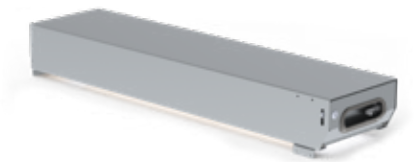

Description	Part#
Parts Drawer	176XXPD

### Top Tray

- Turn your parts drawer top into additional organization
- Add 3 crates (optional)
- 12"W x 48"L x 4"H



Description	Part#
Top Tray	176XXTT
Top Tray With Crates	176XXTWC

### Add a Worktop to Your Drawer System

- 18"D x 48"W hardwood butcher block top



Description	Part#
Drawer System Worktop	176XXWT

### Add a Raise For Long Pipe or Lumber

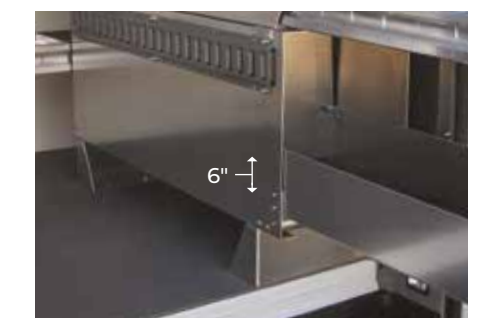

Description	Part#
Raises (set of 2)	176XX6R

## Maximize your Productivity!

Bring all of your small parts in one trip

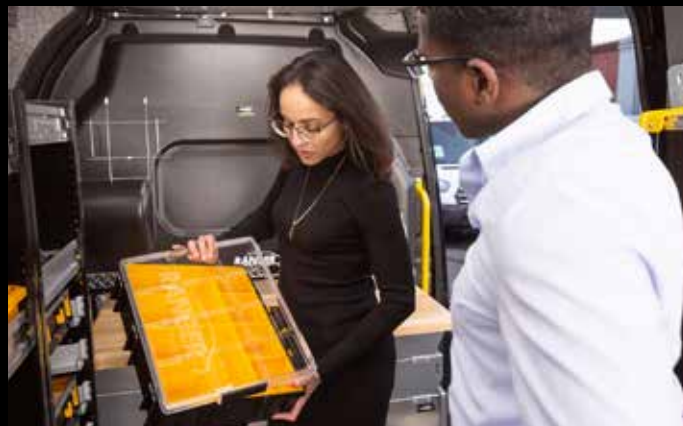

## Incorporate time saving Parts Keepers into your upfit:

1) Add single Parts Keeper units onto your shelves

2) Mount a Parts Keeper cabinet at your side door for easy access



### Parts Keeper Parts Organizer Carry Case

- Includes 8-4"x4" (62-U6205) and 2-4"x8" (62-U6210) bins.
- 16.5"W x 13"W x 4"D



Description	Part#
Parts Keeper Carry Case	176XXPCC

### Single Parts Keeper Unit

- Includes one case
- 3 mounting styles:
  - under shelf,
  - inset into shelf,
  - or stacked
- 14"D x 18"W x 5"H



Description	Part#
Single Parts Keeper	176XXPC

**Be Efficient!**  
Saving just 5 minutes per day will gain you 21 hours per year!

### 4 Pc. Parts Keeper Cabinet

- 14"D x 18"W x 24"H



Description	Part#
4 Pc. Parts Keeper	176XX4PC

### 8 Pc. Parts Keeper Cabinet

- 14"D x 18"W x 43"H
- Available in Steel and Aluminum



Description	Part#
8 Pc. Parts Keeper Steel	176XX8PC
8 Pc. Parts Keeper Aluminum	176XX8PC-A

### 8 pc. Parts Keeper with two shelves

- 14"d x 19"w x 62"h
- Available in Steel and Aluminum



Description	Part#
8 Pc. Parts Keeper Steel	176XX8PC
8 Pc. Parts Keeper Aluminum	176XX8PC-A

### 2-Drawer & 3-Drawer Cabinets:

- Latching drawers with ball bearing slides
- Includes key lock for security
- Cabinets can be individually mounted to shelves or stacked on floor
- 12.5"D x 18.5"W x 10.5"H

### 9-Drawer Cabinet:

- Rattle-free plastic drawers with dividers
- Includes built-in drawer catch
- 12.5"D x 17"W x 12"H



Contractor Approved

“The drawers are super smooth and I couldn't be happier with them. High quality item.”

Leslie N.

### 2-Drawer Cabinet



### 3-Drawer Cabinet



### 9-Drawer Cabinet

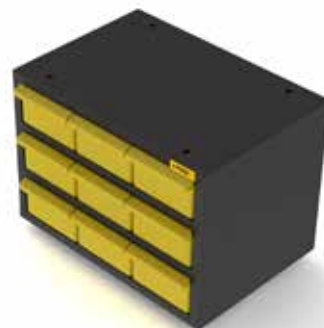

Description	Part#	Description	Part#	Description	Part#
2-Drawer Cabinet	876XX2DC	3-Drawer Cabinet	876XX3DC	9-Drawer Cabinet	876XX9DC

### Locking Door



Description	Part#
36" Locking Door	876XX36LD
42" Locking Door	876XX42LD
48" Locking Door	876XX48LD
60" Locking Door	876XX60LD

### Dividers (pack of 5)



Description	Part#
12" Adjustable Shelf Dividers	876XX12D
14" Adjustable Shelf Dividers	876XX14D
12" Extra-High Shelf Dividers	876XX12HD
14" Extra-High Shelf Dividers	876XX14HD

### Bins



Description	Part#
12"D Plastic Bin	876XX12B
14"D Plastic Bin	876XX14B
Cross Dividers (set of 2)	876XXBD

### Ladder Hook

- Use two to hang ladder from shelving
- Clips to shelving lip



Description	Part#
Ladder Hook	876XXLH

### Swivel Hook



Description	Part#
Swivel Hook	864XXSW

### Fixed Hook



Description	Part#
Fixed Hook	864XXFH

INTERIOR ACCESSORIES

INTERIOR ACCESSORIES

## Cab Organizer Box



Description	Part#
Cab Organizer Box with Raise	876DXCB

## 3-Slot Paper Holder



Description	Part#
Steel 3-Slot Paper Holder	876XX3PH

## First-Aid Kit



Description	Part#
First-Aid Kit With Holder	864XXFA

## Triangle Kit



Description	Part#
Triangle Kit	876XXTK

## Hard Hat Holder



Description	Part#
Hard Hat Holder	876XXHH

## Grab Handle

- High grip surface
- Increase safety and efficiency



Description	Part#
Grab Handle	854DXGH



## Small Bottle Holder

- For MC tanks



Description	Part#
Small Bottle Holder	864XXSBH

## Large Bottle Holder

- For B tanks and nitrogen tanks



Description	Part#
Large Bottle Holder	864XXLBH

## Refrigerant Rack Three Level

- For 30lb and 50lb refrigerant tanks



Description	Part#
Refrigerant Rack 3 Tier	876XX3BH

## Refrigerant Rack Four Level

- For 30lb refrigerant tanks



Description	Part#
Refrigerant Rack 4 Tier	876XX4BH

## Refrigerant Rack Five Level

- For 30lb and 50lb refrigerant tanks



Description	Part#
Refrigerant Rack 5 Tier	876XX5BH

INTERIOR ACCESSORIES

INTERIOR ACCESSORIES

# Side Dropdown Ladder Rack

# Rear Dropdown Ladder Rack

## Max Rack

optional cross bar end stops available for a single sided rack for additional roof storage capacity



Single Side Drop Down



Double Side Drop Down



- All aluminum construction
- Removable rotation bar included
- Single side rack holds 1 extension ladder
- Double side rack holds 2 extension ladders
- Maximum extension ladder 32 feet
- Add optional third crossbar to hold stepladders, fits 8-10 foot stepladders only

Description	Single Sided Part#	Double Sided Part#
118 WB	376D2SR	376D2DR
136 WB	376D3SR	376D3DR
159 WB	376D5SR	376D5DR
159 WB Ext	376D6SR	376D6DR
Max Rack 2.0 Third Crossbar	-	376XXSCB

## Ergo Rack



- Aluminum and steel construction
- Removable rotation bar included
- Single side rack holds 1 extension ladder
- Double side rack holds 2 extension ladders
- Maximum extension ladder size is 36 foot
- Add optional third crossbar to hold stepladders, fits 6-10' foot stepladders only



Single-Side Drop Down

Description	Part#
Single-Side Drop Down	374DXSR



Double-Side Drop Down

Description	Part#
Double-Side Drop Down	374DXDR
Ergo Rack Third Crossbar	374XXSCB

## Access Stow



- Rust-free aluminum and stainless construction
- Fast, easy operation
- Ergonomic and safe rear deployment
- Works for extension ladders up to 32' or step ladders up to 10'

Single Rear Deploy



Double Rear Deploy



Description	Single Access Stow	Double Access Stow
118" WB Low Roof	376D2SS	376D2DS
136"WB Low Roof	376D3SS	376D3DS
136"WB High Roof	376D4SS	376D4DS
159"WB High Roof	376D5SS	376D5DS
159"WB Ext High Roof	376D6SS	376D6DS

## Our 6 Step Process

Start with <b>Interior Finishing</b> 01	Add <b>Safety and Security</b> 02	Choose your <b>Shelving Package</b> 03
Add time-saving <b>Interior Accessories</b> 04	Select your <b>Roof Equipment</b> 05	Finish with <b>Exterior Accessories</b> 06

## Roof Decks

- Heavy duty anodized aluminum construction
- Aerodynamically designed
- Includes rear roller
- Optional ratchet tie downs to secure any type of load



Model	Part#
118" WB Low Roof	376D3RD
136" WB High Roof	376D3RD
159" WB High Roof	376D5RD
159" WB Ext High Roof	376D6RD
Set of Two Ratchet Tie Downs	376XXRTD

## Access Ladders



Bolt-on



Clamp-on

- Heavy duty extruded aluminum
- Contoured to fit ProMaster
- White bolt-on ladder recommended for cargo racks
- Anodized clamp-on ladder recommended for roof decks

Model	Bolt-on Part#	Clamp-on Part#
Low Roof	795DXALW	774DXALL
High Roof	795DXALW	774DXALH

## Cargo Racks

- Rust-free aluminum construction
- Includes ladder stops & straps
- Optional rear roller to aid in loading and protect brake lights



\*optional rear roller bar



Model	Part#
2 Bar Rack	395DX2B
3 Bar Rack	395DX3B
Rear Roller	395DXRR

## Conduit Carrier

- 5" square rigid one piece design
- White powder-coated aluminum with black end caps
- Inside length of 10' 8"
- Lockable
- Add to any ladder rack



Description	Part#
Conduit Carrier	774XXCT

## Ratchet Tie-Downs

- Recommended two per side
- Safely secure any type of load



Model	Part#
Set of 2 for Roof Decks	376XXRTD
Set of 2 for Cargo Racks	795XXRTH1S

## Grip Step Running Boards

- 7" wide stepping surface
- Black powder coat aluminum
- Open tread design for maximum grip
- 98" passenger's board and 36" drivers board



Description	Part#
Running Boards (Driver's side and passenger's side set)	760DXSDX

## Grip Step Rear Step

- Black powder-coated aluminum
- 7" wide stepping surface
- High traction open tread design



Description	Part#
Grip Step Rear Step	760DXBAS

\* Rear steps not compatible with a hitch

## Max Step Rear Step

- Heavy-duty steel frame
- Anti-slip plastic treads
- Reflective strip

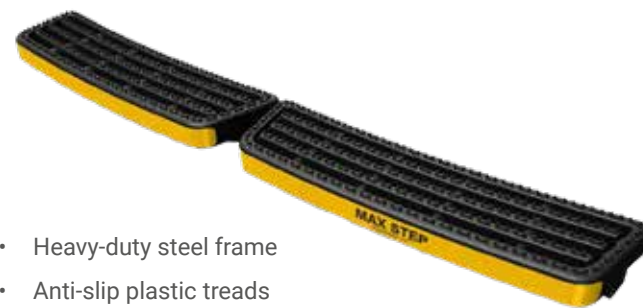

Description	Part#
Max Rear Step	776DXBAS

\* Rear steps not compatible with a hitch

## Tow Hitches

- Class III (600 lb tongue weight, 6000 lb trailer weight)
- 4-way flat & 7-way wiring systems

\* WARNING: Requires a Digital Brake Controller to enable trailer brakes.

Description	Part#
Hitch – Class III Hitch for All Models	706DXTH
4-Way Flat Wiring Kit	506DX4TC
Duplex 7-way/4-way Wiring Kit*	506DX7TC
Digital Brake Controller	506XXTBC



Duplex 4-Way Flat & 7-Way Wiring



Digital Brake Controller

## Windows

- OEM fit
- Light smoke tint



Description	Part#
Rear LH & RH	743DXRW
Driver's Side Forward	743D3DSFW
Sliding Door	743D3SDW
Porthole	732XXPW



## Hasp Locks

- High security shielded hasps
- Solid steel "puck" style locks included

## Slick Locks

- High security hasps use factory mounting points
- Solid steel "puck" style locks included
- Custom fit for drill-free installation

Description	Hasp Lock Part#
Hasp locks (set of 2)	758XXHL
Slick locks (set of 2)	788DXSL



Hasp Lock



Slick Lock



## HVAC Tie-In System

- Engine-driven system designed for generally moderate climates
  - Achieve an indoor temperature approximate 12-15 degrees below the maximum outside temperature
  - Adds a high-capacity evaporator in the cargo area
  - Ties in to vehicle's existing OEM compressor and condenser
  - Connects into vehicle's existing coolant lines for heat function
- Application Example:**
- Art Transport
  - Mobile Showrooms



**NOTE.**  
Products shown on this page are not available for onsite install

Description	Part#
Tie-In HVAC System	997XXTI

## HVAC Extreme Climate System

- Engine-driven system designed for the most demanding HVAC requirements
  - Achieve an indoor temperature of up to 30 degrees below the maximum outdoor temperature
  - Adds a high-capacity evaporator in the cargo area
  - Adds a powerful auxiliary compressor in the engine compartment
  - Adds an additional condenser (either rooftop mount or underbody options)
  - Connects into vehicle's existing coolant lines for heat function
- Application Example:**
- Animal Transport
  - Mobile Labs



Description	Part#
HVAC Extreme Climate System	Call for details

## Fuel-fired Heaters

- High-performance combustion heater for safe, reliable heat
  - Powered through the vehicles existing fuel tank
  - Gas and diesel options
  - Pair with our auxiliary battery/charging system for vehicle-off operation
  - Compact design mounts almost anywhere on the floor
  - Uses as little as 1 gallon of fuel per 22 hour period
  - Up to 7,000 BTU/h heat output
- Application Example:**
- Carpet Cleaners
  - Mobile Pressure-Washers

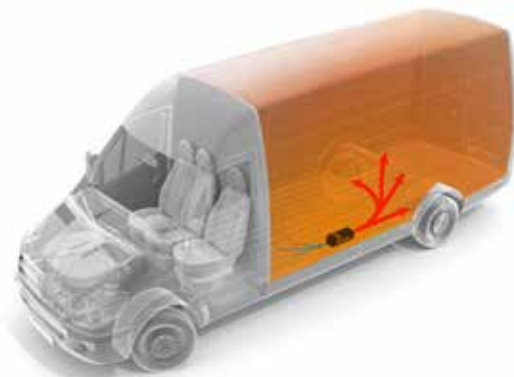

Description	Part#
Fuel-Fired Heater, gas engines, with Standard Controller	997XXGSC
Fuel-Fired Heater, gas engines, with Programmable Controller	997XXPSC
Fuel-Fired Heater, diesel engines, with Standard Controller	997XXDSC
Fuel-Fired Heater, diesel engines, with Programmable Controller	997XXPSC

## Compact Power Inverters

- Pure Sine Wave – safe for electronics and lithium-ion chargers
- 1,200W - 2,000W options
- Perfect for occasional and light/medium loads
- Runs most basic hand tools, chargers, and small appliances
- Single GFCI outlet built into unit



**NOTE.**  
Products shown on this page are not available for onsite install

Description	Part#
1,200W Pure Sine Wave Inverter with cabling & fuse	596XX1.2PI
Bluetooth Adaptor for 1,200W Inverter	596XXBD
Remote Switch for 1,200W Inverter	596XXRS
2,000W Pure Sine Wave Inverter with cabling & fuse	503XX2PI-HF
Remote Switch for 2,000W Inverter	503XXRS

## Heavy Duty Power Inverter/Charger Systems

- Designed for daily use in industrial applications
- 3,000W - 10,000W options
- Perfect for utilities, mobile workstations, and high-surge loads
- Hardwire only - configure with multiple outlets and shore power charging
- Bluetooth-enabled plus remote monitoring options



\*110V outlets and shore power inlet not included – call to configure

Description	Part#
3000W Pure Sine Wave Inverter/Charger* with cabling & fuse	596XX3PI
5000W Pure Sine Wave Inverter/Charger* with cabling & fuse	596XX5PI
Digital Remote Control Panel	596XXRC

## Auxiliary Batteries

- Enables inverter operation with vehicle off
- Provides reserve power for high-surge loads
- 100AH-460AH battery bank options
- Isolated from OEM battery for reliable starts
- Automatically charged via vehicle alternator or optional shore power



Description	Part#
100AH AGM Deep-Cycle Battery with Isolator and Battery Box	503XX1AB-B
200AH AGM Deep-Cycle Battery with Isolator and Battery Box	503XX2AB-B
Battery Monitor – Bluetooth enabled	596XXBMS

## Cantilever Series



- Most popular model
- 1300lb capacity
- Folds to allow rear door access while stowed
- 53"W x 60"L Load Area
- Built in cart stops

## V2 Series

- 1100lb capacity
- Stores inside vehicle
- 47"W x 49"L Load Area
- Built in cart stops



**NOTE.**  
Products shown on this page are not available for onsite install

Description	Part#	Description	Part#
All ProMasters (except 3500 Extended vans)	921DXCS	All ProMasters (except 3500 Extended vans) *	989DXV2
3500 Extended ProMaster	921D6CS	3500 Extended ProMaster *	989D6V2

\* Available on special order only

## Don't see what you're looking for?

Contact us to design a custom build, we love a challenge!



**Mobile Laboratory**

**Challenge:** A manufacturer was looking to perform climate controlled hydraulic tool calibration onsite for their customers.



**Incident Command**

**Challenge:** A regional OEM was looking to manage agency communications and radio distribution at major emergency scenes.



**Mobile Showroom**

**Challenge:** A luxury stone & tile distributor was looking to grow their business by bringing their showroom to their clients.

## 118" WB

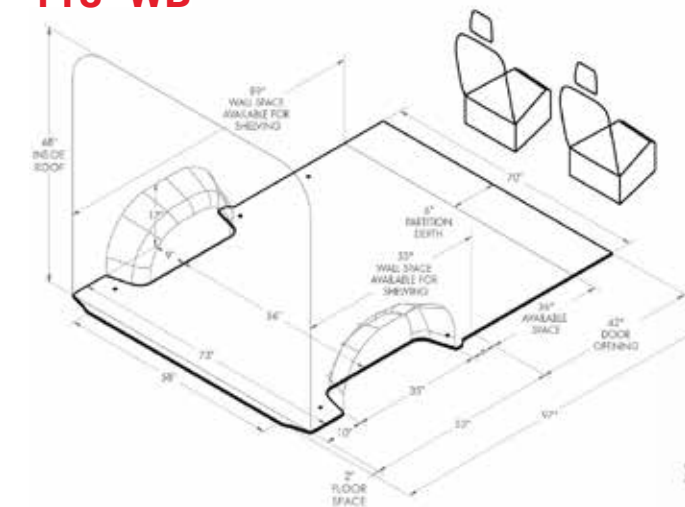

## 136" WB

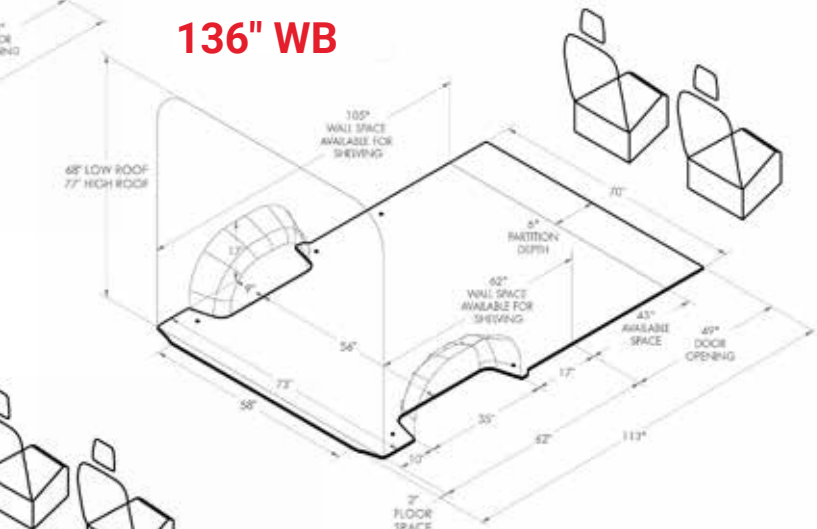

## 159" WB

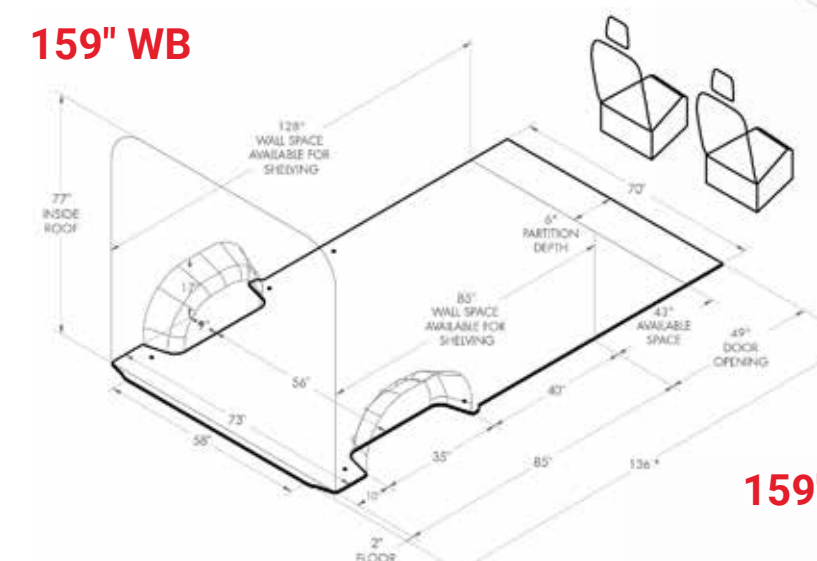

## 159" EXT WB

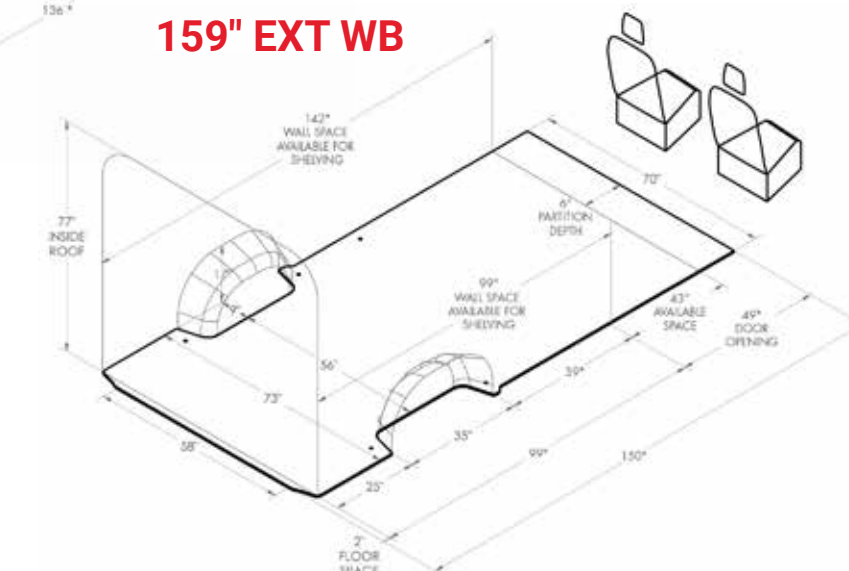

# 7500+

## Vans Upfitted Per Year

### Your ProMaster Customizing Starts Here.

Let Advantage Outfitters make your van work ready!

**95%** Stock Orders Completed in 48 Hours or Less



*Serving the tri-state region*

New York · New Jersey · Connecticut · Pennsylvania

Contact Your RAM Dealer



**WEST**  
255 West Street  
South Hackensack,  
NJ 07606

**EAST**  
107 E. Hawthorne Ave.  
Valley Stream,  
NY 11580

[sales@advantageoutfitters.com](mailto:sales@advantageoutfitters.com)

866.925.4844

[advantageoutfitters.com](http://advantageoutfitters.com)