

Transit Connect

Upfit Guide



**WORK VEHICLES
THAT WORK BETTER!**

advantage
OUTFITTERS

Introduction

What's the Advantage?



We make it Easy

- Simplified layout and design process
- Technical support and configuration assistance

We make it Fast

- Everything in this catalog is in stock
- Installs within 48 hours or less

We make it Last

- Certified and trained Installers
- Lifetime Installation Warranty

Advantage Outfitters is a commercial vehicle upfitter, specializing in storage equipment and accessories for cargo vans. With 20+ years of experience, we have earned the trust of contractors, trade fleets, utilities, municipalities, vehicle dealers, and leasing companies. We are defined by our strong team spirit and our passion for making work vehicles work better.



sales@advantageoutfitters.com

866.925.4844

advantageoutfitters.com

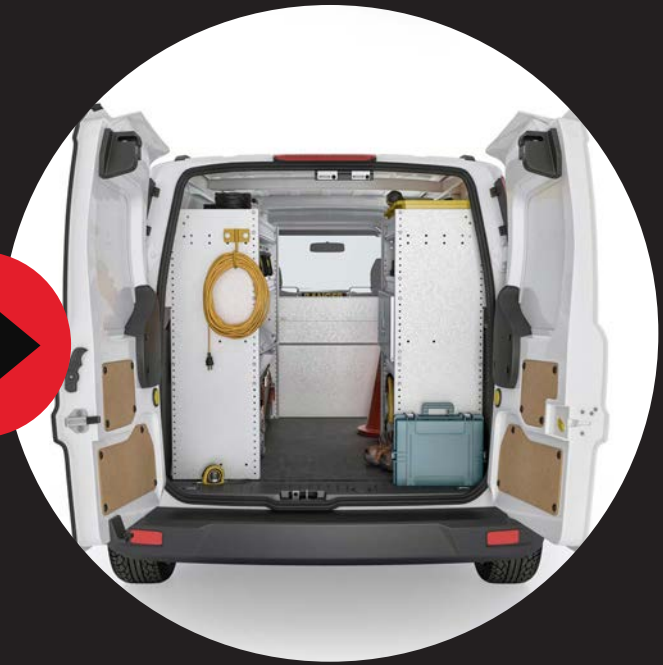

Contents

Interior Finishing	04 - 05
Wall Liners	04
Flooring / Interior Lighting	05
Safety Partitions	06 - 09
Straight & Contoured Partitions	06
Door Security / Reverse Driving Safety	07
Shelving Packages	08 - 13
Base	10
General Service	11
Plumbing & HVAC	12
Electrical	13
Aluminum	14

Interior Accessories	15 - 20
Side-Door Drawer Systems	15
Parts Keepers	16
Drawer Cabinets	17
Shelving Accessories	18
Cab Accessories	19
Bottle Holders	20
Roof Equipment	21 - 22
Clamp Down Ladder and Cargo Racks	21
Roof Decks and Conduit Carrier	22
Vehicle Layouts	23

Wall Liners

Wall & Door Liners

- Protect your vehicle investment
- 3/16" gray plastic
- Highly durable & impact resistant

Note: Full interior liner kits and insulation kits are available. Call for details.



Model	Wall Liners Part#	Door Panels Part#
Short WB	601C1WL	601C1DP
Long WB	601C2WL	601C2DP

Floor Protection

StabiliGrip Floor:

- 3/8" hard plastic with fiberglass reinforcement
- Provides firm base for tools and equipment
- Durable, non-skid surface

Door Sills (optional):

- Custom fit, heavy-duty diamond plate aluminum sill plates



Side Door Sills (optional)



Rear Door Sill (optional)

Model	StabiliGrip Part#
Short WB	654C1SG
Long WB	654C2SG

Description	Door Sill Part#
Rear & Side Sliding Doors	654C2RSS

Interior Lighting

- High intensity 2' LED light
- 800 lumens
- Ultra low power draw
- Wired with OEM switch

Description	Part#
Single 2' LED light	452XXLD2



Partitions



MaxView Partition

- Composite construction
- Contoured design with 10" setback gives maximum seatback travel & floor space
- Clear upper for visibility into rear



Description	Part#
MaxView Partition	276XCWP

Wire Mesh Partition

- Galvanized steel with black painted mesh
- Contoured design with 10" setback gives maximum seatback travel & floor space



Description	Part#
Wire Mesh Partition	276XMP

Contoured Solid Partition

- Galvanized steel
- Contoured design with 10" setback gives maximum seatback travel & floor space
- Solid panel for maximum security

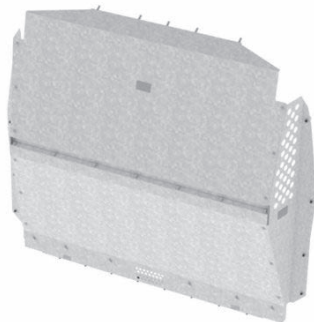

Description	Part#
Contoured Solid Partition	276XCPC

Contoured Partition with Window

- Galvanized steel
- Contoured design with 10" setback gives maximum seatback travel & floor space
- Mesh upper for visibility into rear

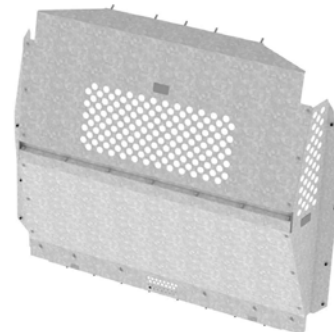

Description	Part#
Contoured Partition with Window	276CXWP

Door Security

Slick Locks

- High security hasps use factory mounting points
- Solid steel “puck” style locks included
- Custom fit for drill-free installation

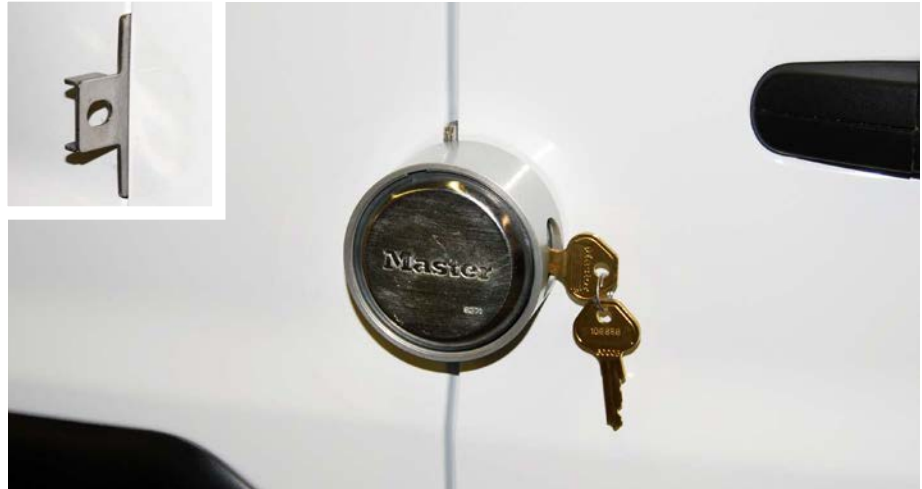

Description	Part#
Cargo Doors (set of 3)	788CXSL

Reverse/Driving Safety

Reverse Sensors

- 4 bumper mount sensors
- Digital LED display with audio alarm



Description	Part#
Reverse Sensors	580XRVS

Back-up Alarm

- 97 dba
- Commercial grade



Description	Part#
Back-up Alarm	594XXBU

Window Grills

- Black painted wire mesh construction

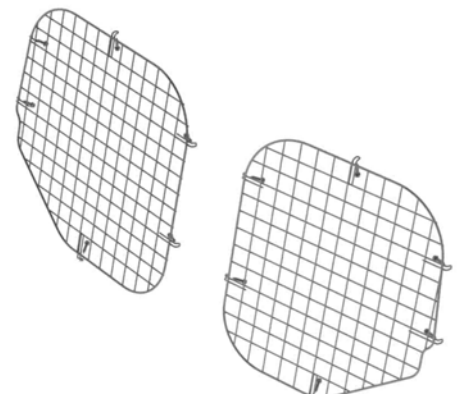

Description	Part#
Rear Doors	876CXRG

Strong...
Lightweight...
Quiet...
Customizable...

Up to 40% weight savings versus
comparable steel packages



What's our Shelving Advantage?

Durable



Load tested to
1200 lbs
per shelf

Secure

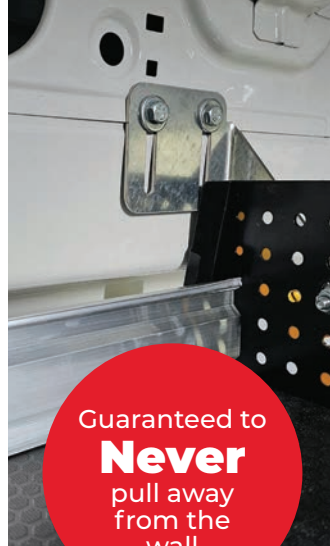

Guaranteed to
Never
pull away
from the
wall

Lightweight

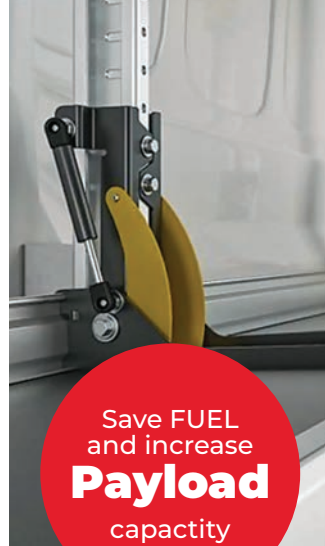

Save FUEL
and increase
Payload
capacity

Quiet

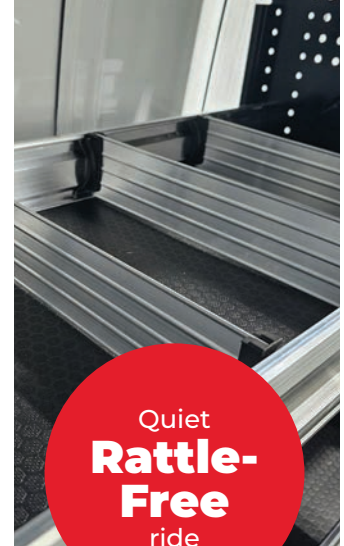

Quiet
Rattle-Free
ride

Here's what our customers say about their upfitted vans

"My technicians are able to keep the vans organized, which increases our overall efficiency."

Mike S.
HVAC Service Company.



"You really helped us get the maximum benefit out of our vehicles."

Michael R.
Fire Protection Company.



Shelving Packages

Base Package

Wire Mesh Partition

Driver's side includes:

- (1) 42"H x 36"L 3-shelf shelving unit

Passenger's side includes:

- (1) 42"H x 36"L 3-shelf shelving unit



Description	Part#
Base Package (Wire Mesh Partition)	276CXB

General Service Package

Contoured Partition with Perforated Window

Driver's side includes:

- (1) 42"H x 36"L 3-shelf shelving unit
- (10) adjustable 3" rattle-free dividers
- (2) 17"W x 12"H 9-drawer cabinets
- (1) fixed hook

Passenger's side includes:

- (1) 42"H x 36"L 3-shelf shelving unit
- (3) 14"D x 12"W plastic bins
- (1) swivel hook

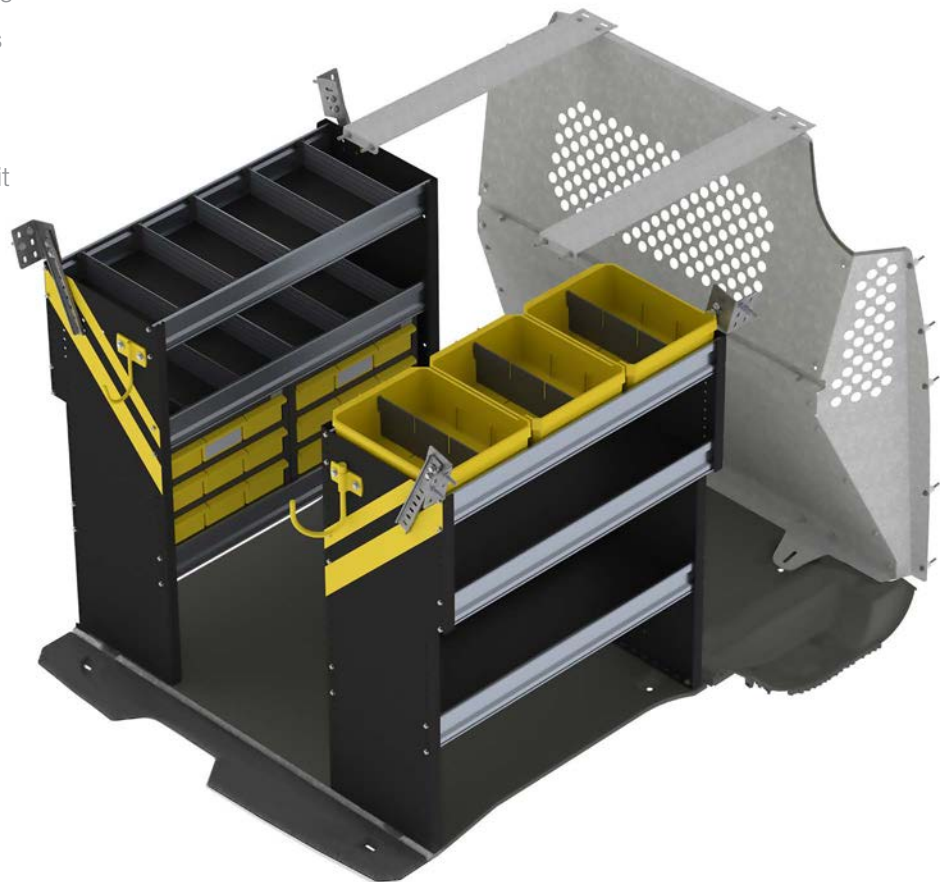

Description	Part#
General Service Package (Contoured Partition with Perforated Window)	276CXGSP

Shelving Packages

Plumbing/HVAC Package

Contoured Partition with Perforated Window

Driver's side includes:

- (1) 42"H x 36"L 3-shelf shelving unit
- (2) 17"W x 12"H 9-drawer cabinets
- (1) fixed hook

Passenger's side includes:

- (1) 42"H x 36"L 3-shelf shelving unit
- (10) adjustable 3" rattle-free dividers
- (1) 43"H x 10.5"W 4-tier refrigerant rack for bottles
- (1) swivel hook



Description	Part#
Plumbing/HVAC Package (Contoured Partition with Perforated Window)	276CXHP

Electrical Package

Contoured Partition with Perforated Window

Driver's side includes:

- (1) 42"H x 36"L 3-shelf shelving unit
- (5) adjustable 3" rattle-free dividers
- (1) 11"H x 36"L locking cabinet
- (1) fixed hook

Passenger's side includes:

- (1) 42"H x 36"L 3-shelf shelving unit
- (3) 12"D x 12"W plastic bins
- (6) 14"D x 12"W plastic bins
- (6) cross dividers for bins
- (1) swivel hook

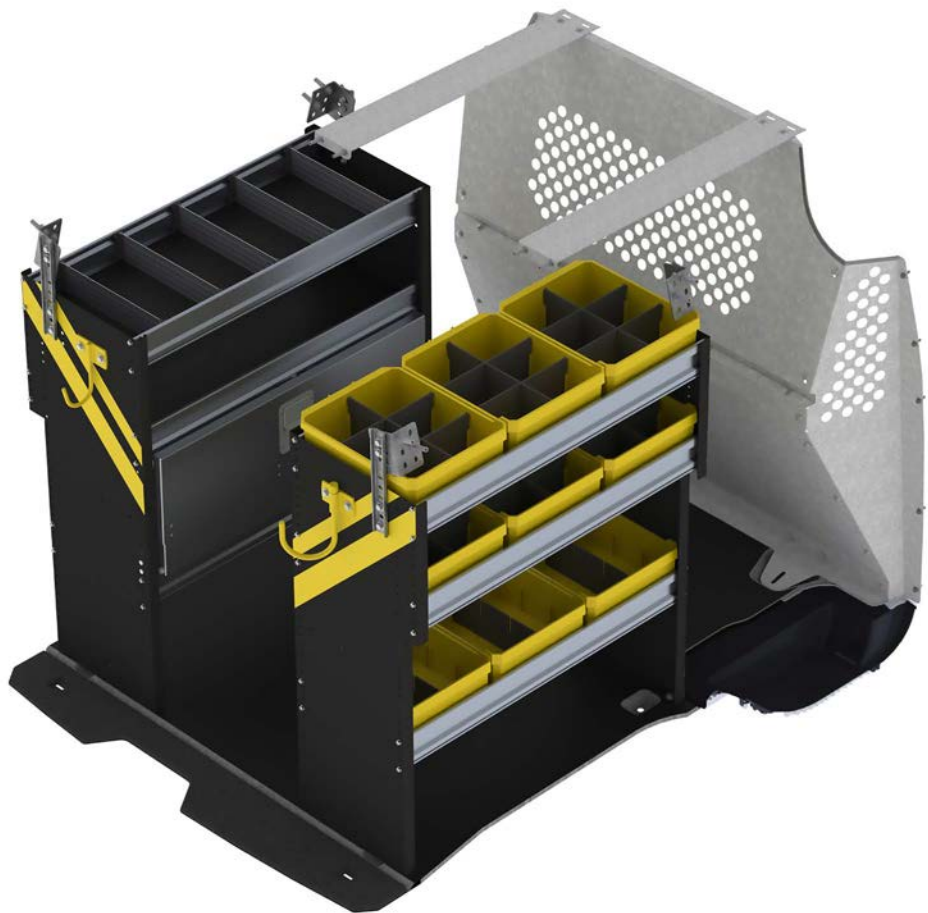



Description	Part#
Electrical Package (Contoured Partition with Perforated Window)	276CXEP

Shelving Packages

Aluminum Shelving

Ultra-lightweight all-aluminum packages are also available!

Weight saving equipment reduces total cost of ownership:

-  Optimize fuel economy by decreasing overall van mass
-  Reduce vehicle maintenance and repairs caused by weight overload
-  Increase payload without sacrificing quality — it's a benefit offered only by aluminum



Don't See It? Just Ask!

We Also Provide:

- Thermal Insulation
- Exterior Lighting
- Power Inverters
- Climate Control
- Ventilation
- Electrical Systems
- Mobile Workspaces
- Cargo Ramps

And Much More!

Save Time and Get Organized!

Access your most common items without even entering your vehicle.



Tool Drawer

- 320 lb capacity
- Open interior for tool bags & cases
- 14"W x 48"L x 16"H



Description	Part#
Tool Drawer	176XXSTD

Parts Drawer

- 150 lb capacity
- Dividers for parts and hand tools
- Stack 1, 2 or 3 above your jumbo tool drawer
- 12"W x 48"L x 6"H



Description	Part#
Parts Drawer	176XXPD

Top Tray

- Turn your parts drawer top into additional organization
- Add 3 crates (optional)
- 12"W x 48"L x 4"H



Description	Part#
Top Tray	176XXTT
Top Tray With Crates	176XXTWC

Add a Worktop to Your Drawer System

- 18"D x 48"W hardwood butcher block top



Description	Part#
Drawer System Worktop	176XXWT

Add a Raise For Long Pipe or Lumber

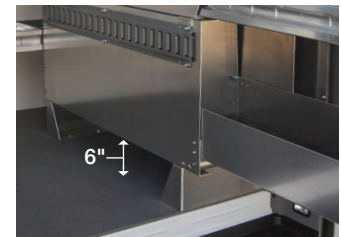

Description	Part#
Raises (set of 2)	176XX6R

Parts Keepers

Be Efficient!

Saving just 5 minutes per day will gain you 21 hours per year!

Single Partskeeper Unit

- Includes one case
- 3 mounting styles: under shelf, inset into shelf, or stacked
- 14"D x 18"W x 5"H

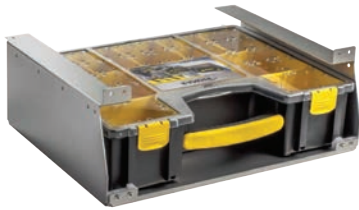

Description	Part#
Single Partskeeper	176XXPC



4 Pc. Partskeeper

- 14"D x 18"W x 24"H



Description	Part#
4 Pc. Partskeeper	176XX4PC

5 Pc. Partskeeper

- 14"D x 18"W x 43"H



Description	Part#
5 Pc. Partskeeper	176XX5PC

8 Pc. Partskeeper

- 14"D x 18"W x 43"H



Description	Part#
8 Pc. Partskeeper	176XX8PC

2-Drawer & 3-Drawer Cabinets:

- Latching drawers with ball bearing slides
- Includes key lock for security
- Cabinets can be individually mounted to shelves or stacked on floor
- 12.5"D x 18.5"W x 10.5"H

9-Drawer Cabinet:

- Rattle-free plastic drawers with dividers
- Includes built-in drawer catch
- 12.5"D x 18.5"W x 10.5"H

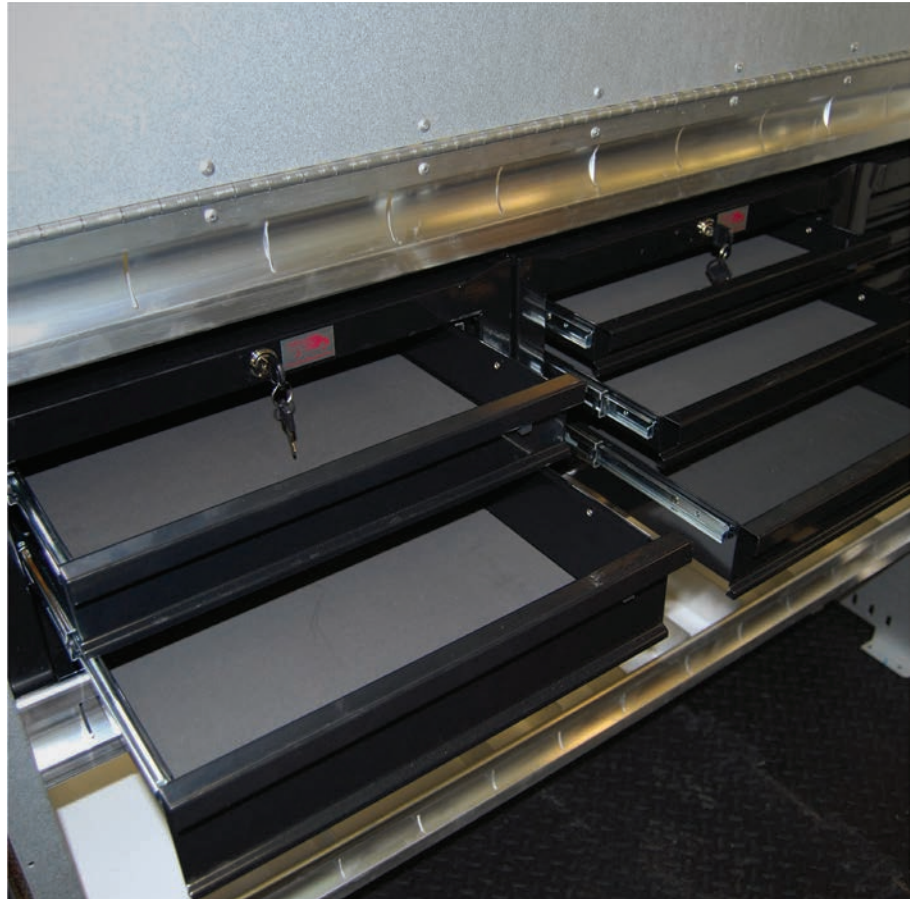

2-Drawer Cabinet

3-Drawer Cabinet

9-Drawer Cabinet

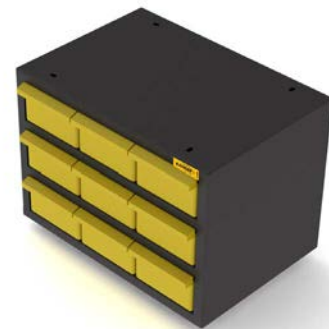

Description	Part#
2-Drawer Cabinet	876XX2DC

Description	Part#
3-Drawer Cabinet	876XX3DC

Description	Part#
9-Drawer Cabinet	876XX9DC

Shelving Accessories

Locking Doors



Description	Part#
36" Locking Door	876XX36LD
42" Locking Door	876XX42LD
48" Locking Door	876XX48LD
60" Locking Door	876XX60LD

Dividers (pack of 5)



Description	Part#
10" Adjustable Shelf Dividers	876XX10D
12" Adjustable Shelf Dividers	876XX12D
14" Adjustable Shelf Dividers	876XX14D

Bins



Description	Part#
10"D Plastic Bin	876XX10B
12"D Plastic Bin	876XX12B
14"D Plastic Bin	876XX14B
Cross Dividers (set of 2)	876XXBD

Ladder Hook



Description	Part#
Ladder Hook	876XXLH

Swivel Hook



Description	Part#
Swivel Hook	864XXSW

Fixed Hook



Description	Part#
Fixed Hook	864XXFH

First-Aid Kit



Description	Part#
First-Aid Kit With Holder	864XXFA

Seat Covers

- Custom-fit
- Tough Cordura fabric



Description	Part#
Seat Covers (set of 2)	876CXSC

3-Slot Paper Holder

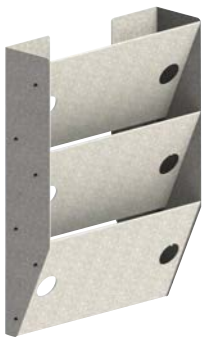

Description	Part#
Steel 3-Slot Paper Holder	876XX3PH

Hard Hat Holder



Description	Part#
Hard Hat Holder	876XXHH

Triangle Kit



Description	Part#
Triangle Kit	876XXTK

Bottle Holders

Four Level Bottle Holder:

- For 30lb refrigerant tanks

Small Bottle Holder:

- For MC tanks

Large Bottle Holder:

- For B tanks and nitrogen tanks

Four Level Bottle Holder



Description	Part#
Four Level Bottle Holder	876XX4BH



Small Bottle Holder



Description	Part#
Small Bottle Holder	864XXSBH

Large Bottle Holder



Description	Part#
Large Bottle Holder	864XXLBH

Clamp Down Ladder Rack

- Includes front, middle and rear crossbars for long and short ladders
- Makes loading and unloading ladders an easy, one-person operation
- Ladders are restrained by rotating handle and padlock can be added for extra security



Model	Part#
Clamp Down Ladder Rack	376CXCR

Cargo Racks

- Rust-free aluminum construction
- Includes ladder stops & straps



Add an optional rear roller bar

Model	Part#
2 Bar Rack	395CX2B
3 Bar Rack	395CX3B
Rear Roller	395CXRR

Roof Decks & Cargo Racks

Roof Deck

- Heavy duty anodized aluminum construction
- Aerodynamically designed
- Includes rear roller



Model	Part#
Roof Deck	376C2RD

Conduit Carrier

- 5" square rigid one piece design
- White powder-coated aluminum with black end caps
- Inside length of 10' 1"
- Lockable
- Add to any ladder rack



Description	Part#
Conduit Carrier	774XXCT

Short WB

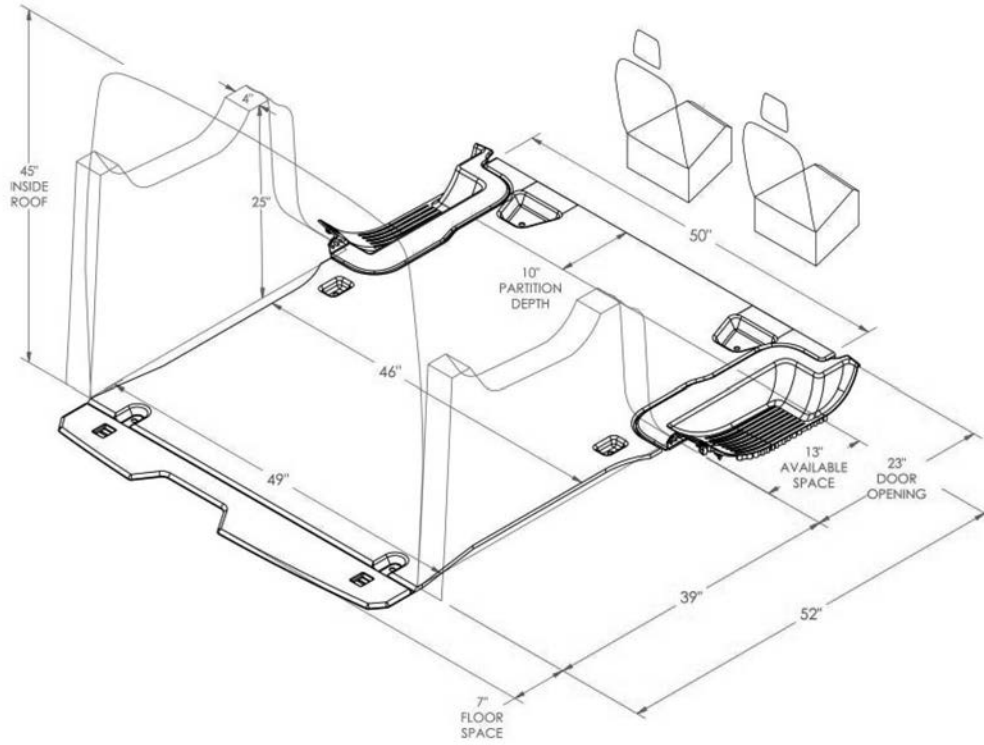

Long WB

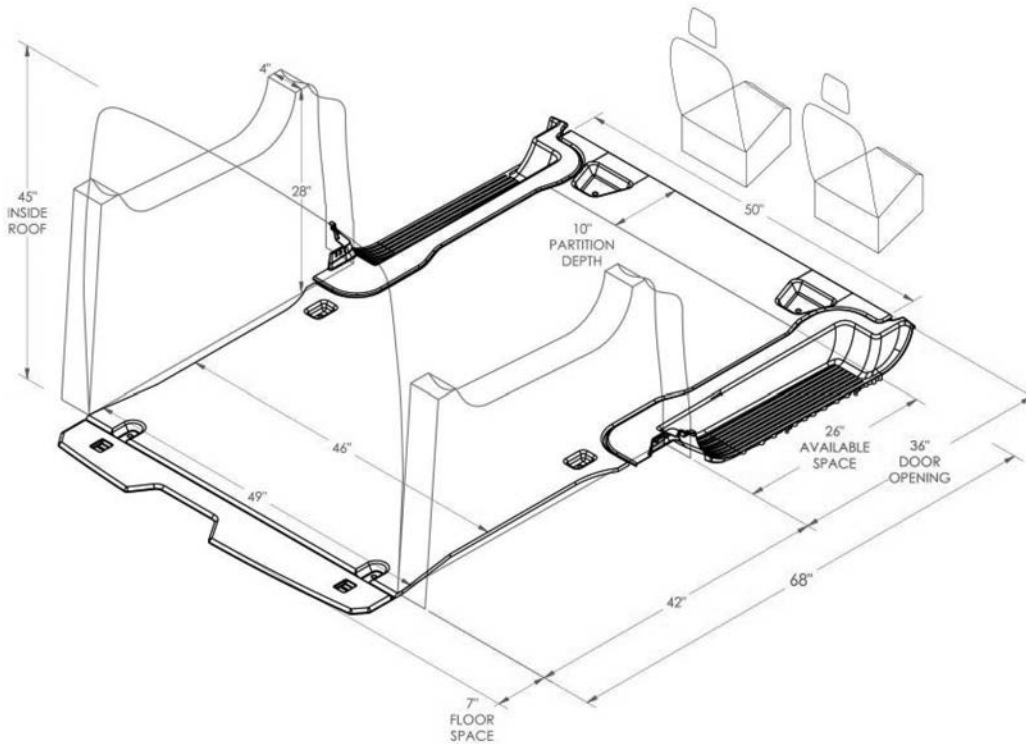

7500+

Vans Upfitted Per Year

Your Transit Connect Customizing Starts Here.

Let Advantage Outfitters make your van work ready!

95% Stock Orders Completed in 48 Hours or Less



Serving the tri-state region

New York • New Jersey • Connecticut • Pennsylvania

Contact Your Transit Dealer



WEST
255 West Street
South Hackensack,
NJ 07606

EAST
107 E. Hawthorne Ave.
Valley Stream,
NY 11580

sales@advantageoutfitters.com

866.925.4844

advantageoutfitters.com