

ProMaster

Upfit Guide



NOW FEATURING

Packd Products

**WORK VEHICLES
THAT WORK BETTER!**

advantage
OUTFITTERS

What's the Advantage?



We make it Easy

- Simplified layout and design process
- Technical support and configuration assistance

We make it Fast

- Everything in this catalog is in stock
- Installs within 48 hours or less

We make it Last

- Certified and trained Installers
- Lifetime Installation Warranty

A simple 6 step process to an efficient work van

01. Start with **Interior Finishing**
02. Add a **Safety Partition**
03. Choose your **Shelving Package**
04. Add time-saving **Interior Accessories**
05. Select your **Roof Equipment**
06. Finish with **Exterior Accessories**

Advantage Outfitters is a commercial vehicle upfitter, specializing in storage equipment and accessories for cargo vans. With 20+ years of experience, we have earned the trust of contractors, trade fleets, utilities, municipalities, vehicle dealers, and leasing companies. We are defined by our strong team spirit and our passion for making work vehicles work better.



Contents

Interior Finishing	04 - 07	Interior Accessories	19-25
Wall Liners	04	Side-Door Drawer Systems	19
Flooring	05	Parts Keepers	20-21
Lashing / Seat Covers / Window Grills	06	Drawer Cabinets	22
Interior Lighting	07	Shelving Accessories	23
Safety Partitions	08 - 09	Cab Accessories	24
Straight Partitions	08	Bottle Holders	25
Contoured Partitions	09	Roof Equipment	26 - 29
Shelving Packages	12 - 17	Side Dropdown	26
Base	12	Rear Dropdown	27
General Service	13	Roof Decks and Cargo Racks	28
HVAC	14	Ladder Rack Accessories	29
Plumbing	15	Exterior Accessories	30 - 31
Electrical	16	Running Boards / Rear Steps	30
Delivery	17	Hitches / Windows / Locks	31
		Specialty Equipment	32-35
		Climate Control	32
		Inverters	33
		Liftgates	34
		Vehicle Layouts	35



sales@advantageoutfitters.com

866.925.4844

advantageoutfitters.com

VanLiner Wall and Door Protection

- Protect your vehicle investment
- 3/16" light grey plastic with textured finish
- Highly durable & impact resistant



Model	Wall Panels Part#	Door Panels Part#	Model	Wall Panels Part#	Door Panels Part#
118" WB Low Roof	601D2WL	601D2DP	159" WB High Roof	601D5WL	601D4DP
136" WB Low Roof	601D3WL	601D3DP	159" WB Ext High Roof	601D6WL	601D4DP
136" WB High Roof	601D4WL	601D4DP	159" WB Ext Super High Roof	601D7WL	601D4DP

Duratherm Insulated Kits

- 3/8" Heavy duty rigid grey plastic wall protection with 1/8" foil/foam insulation layer
- Provides sound deadening and an R4 equivalent thermal barrier
- Textured surface is scratch and impact resistant



Model	Wall Liners Part#	Door Liners Part#	Ceiling Liners Part#
118" WB Low Roof	654D2WL	654D2DP	654D2CL
136" WB Low Roof	654D3WL	654D3DP	654D3CL
136" WB High Roof	654D4WL	654D4DP	654D4CL
159" WB High Roof	654D5WL	654D4DP	654D5CL
159" WB Ext High Roof	654D6WL	654D4DP	654D6CL
159" WB Ext Super High Roof	654D7WL	654D7DP	654D7CL

Floor Protection

Rubber Mat

- 1/4" virgin rubber resists oils and chemicals
- Saves knees and increases traction
- One piece seamless



Model	Rubber Mat Part#
118" WB	654D2RM
136" WB	654D3RM
159" WB	654D5RM
159" WB Ext	654D6RM

StabiliGrip Floor

- 1/2" hard plastic with fiberglass reinforcement
- Provides firm base for tools and equipment
- Durable, non-skid surface



Model	StabiliGrip Floor Part#
118" WB	654D2SG
136" WB	654D3SG
159" WB	654D5SG
159" WB Ext	654D6SG

Door Sills

- Custom fit, heavy-duty diamond plate aluminum sill plates
- Protects entry points and provides traction

Description	Door Sill Part#
Set of 2 for Sliding Door and Rear Doors	654DXRSS

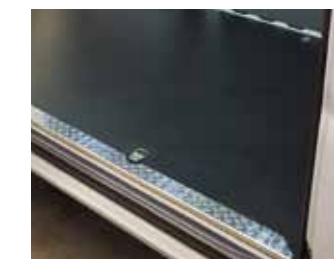

Side Door Sill



Rear Door Sill

Wheel Well Covers

- Decreases road noise and provides a thermal barrier.
- Does not fit 118" WB ProMasters

Description	Part#
Wheel Cover	854DXWWC



INTERIOR FINISHING

INTERIOR FINISHING

Aluminum Lashing Rail

- Durable & versatile
- Single level kits come with 5 movable tie-down rings
- Double level kits come with 10 movable tie-down rings
- Ratchet straps also available



Model	Single Level Part#	Double Level Part#
118" WB LR	842D2LK	-
136" WB LR	842D3LK	-
136" WB HR	842D3LK	842D4LK2
159" WB HR	842D5LK	842D5LK2
159" WB Ext HR	842D6LK	842D6LK2
8' Ratchet Strap	842XX8RB	842XX8RB
6' Cam Buckle Strap	842XX6CB	842XX6CB



Seat Covers

- Custom-fit
- Tough Cordura fabric



Window Grills

- Black painted wire mesh construction

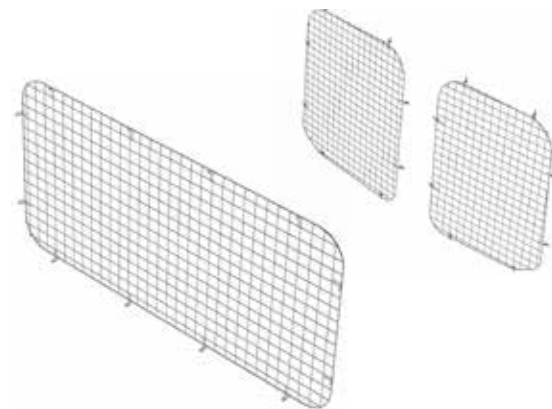

Description	Part#
Seat Covers (set of 2)	876DXSC

Description	Part#
Side Sliding Door	876DXSG
Rear Doors (set of 2)	876DXRG

Strip Lighting

- High intensity 2' LED light
- Mounts to side of ceiling ribs to maintain headroom
- Light is not compatible with ceiling liners
- Wired with OEM (door) switch
- 2 recommended for 118" and 136" WB vans
- 3 recommended for 159" and 159" EXT WB vans



Description	Part#
Single 2' LED light	452XXLD2

Motion Sensor Lighting



Shown with optional bracket.



- Motion sensor activated
- Recommended for install with Duratherm ceilings
- 2 recommended for 118" and 136" WB vans
- 3 recommended for 159" and 159" EXT WB vans

Description	Part#
1 LED light kit	454XXLK1
2 LED lights kit	454XXLK2
3 LED lights kit	454XXLK3
Bracket and hardware kit	454XXBH*

* Required for vans without ceiling

Our 6 Step Process

Start with **Interior Finishing** 01

Add **Safety and Security** 02

Choose your **Shelving Package** 03

Add time-saving **Interior Accessories** 04

Select your **Roof Equipment** 05

Finish with **Exterior Accessories** 06

INTERIOR FINISHING

INTERIOR FINISHING

Partitions Without Door

Steel Partition

- Heavy gauge white powder-coated steel
- Includes hatch in bottom of center panel for long material
- Mesh upper on center & passenger side panels for increased visibility
- 4" setback for seat travel



Steel Partition Without Door



Aluminum Partition Without Door

Aluminum Partition

- Lightweight & durable aluminum
- Rattle-free design
- Mesh upper on center panel
- 4" setback for seat travel

Available with or without center panel.

Description	Part#
Steel Partition Without Door	287DXSP
Aluminum Partition Without Door	P40-RP

Partitions With Door

Steel Partition with Door

- Heavy gauge white powder-coated steel
- Includes hatch in bottom of center panel for long material
- Mesh upper on center & passenger side panels for increased visibility
- 4" setback for seat travel
- Includes hinged locking door for access to cargo area



Steel Partition With Door



Aluminum Partition With Door

Aluminum Partition with Door

- Lightweight & durable aluminum
- Rattle-free design
- Mesh upper on center panel
- 4" setback for seat travel
- Includes hinged latching door for access to cargo area



Description	Part#
Steel Partition With Door	287DXHDP
Aluminum Partition With Door	P50-RP

Composite Partitions

- One-piece design
- Innovative design maximizes both driver comfort and storage space
- Perfect fit provides improved climate control and noise reduction
- Available with or without polycarbonate window (for the straight composite option)



Contoured Composite



Straight Composite (with and without window)

Description	Part#
Contoured Composite	P60-RP
Straight Composite	187DXCP
Straight Composite With Window	187DXCPW

Contoured Aluminum Partitions

- Lightweight & durable aluminum
- Rattle-free design
- Maximize seatback travel while increasing cargo floor area
- Available with or without window for visibility

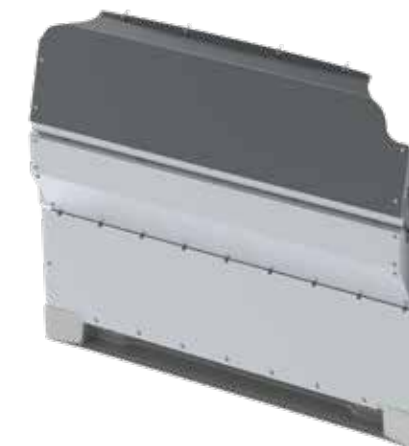

Contoured Solid Partition

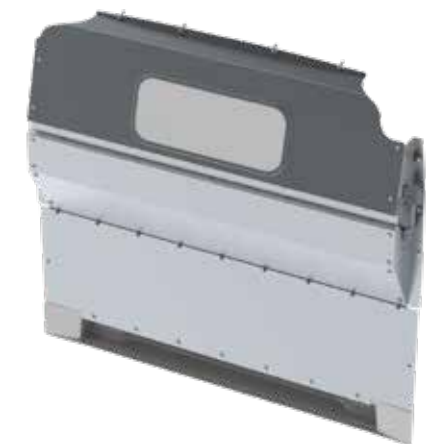

Contoured Partition - Window

Description	Part#
Solid Aluminum Contoured Partition	P10-RP
Aluminum Partition With Window	P11-RP

Increase your productivity with our Trade-Specific Packages



What's the Packd Advantage?



Durable



Load tested to **1200 lbs** per shelf

Secure

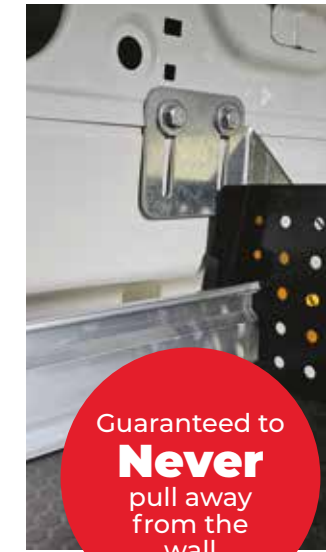

Guaranteed to **Never** pull away from the wall

Lightweight



Save **FUEL** and increase **Payload** capacity

Quiet

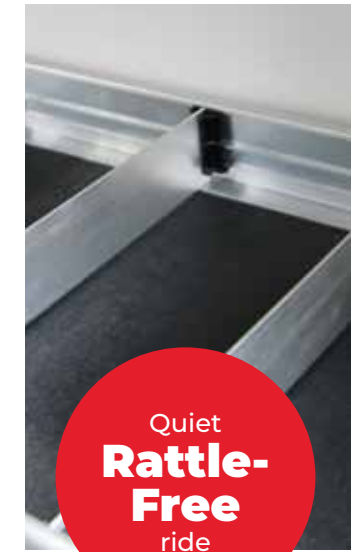

Quiet **Rattle-Free** ride

Here's what our customers say about their outfitted vans

"My technicians are able to keep the vans organized, which increases our overall efficiency."

Mike S.
HVAC Service Company.



"You really helped us get the maximum benefit out of our vehicles."

Michael R.
Fire Protection Company.



Our 6 Step Process

Start with Interior Finishing 01

Add Safety and Security 02

Choose your Shelving Package 03

Add time-saving Interior Accessories 04

Select your Roof Equipment 05

Finish with Exterior Accessories 06

Base Package - 136" WB

Driver's side includes:

- (1) Aluminum 62"H x 84"L 4-shelf shelving unit

Passenger's side includes:

- (1) Aluminum 62"H x 48"L 4-shelf shelving unit



Packd

Partitions And Flooring Are Not Included In Shelving Packages

Description	Part#
Base Package, 136" WB	175D3BPX

General Service Package - 136" WB

Driver's side includes:

- (1) Aluminum 62"H x 84"L 4-shelf shelving unit
- (2) 18.5"W x 10.5"H 2 drawer cabinets
- (10) Aluminum rattle-free dividers
- (1) Fixed Hook

Passenger's side includes:

- (1) Aluminum 62"H x 48"L 4-shelf shelving unit
- (4) 12"D plastic bins with center divider & cross divider
- (1) 8" swivel hook (4" opening)



Packd

Partitions And Flooring Are Not Included In Shelving Packages

Description	Part#
General Service Package, 136" WB	175D3GSPX

Base Package - 159" WB

Driver's side includes:

- (1) Aluminum 62"H x 96"L 4-shelf shelving unit

Passenger's side includes:

- (1) Aluminum 62"H x 60"L 4-shelf shelving unit

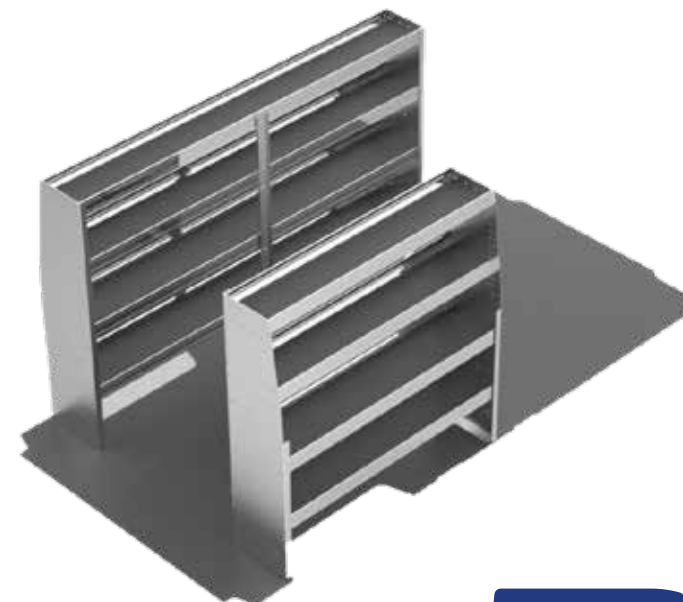

Packd

Partitions And Flooring Are Not Included In Shelving Packages

Also Available for 118" WB

Base Package Part# 175D2BPX

Description	Part#
Base Package, 159" WB	175D5BPX

General Service Package - 159" WB

Driver's side includes:

- (1) Aluminum 62"H x 96"L 4-shelf shelving unit
- (2) 18.5"W x 10.5"H 2 drawer cabinets
- (10) Aluminum rattle-free dividers
- (1) Fixed Hook

Passenger's side includes:

- (1) Aluminum 62"H x 60"L 4-shelf shelving unit
- (5) 12"D plastic bins with center divider & cross divider
- (1) 8" swivel hook (4" opening)



Packd

Partitions And Flooring Are Not Included In Shelving Packages

Also Available for 118" WB

General Service Package Part# 175D2GSPX

Description	Part#
General Service Package, 159" WB	175D5GSPX

HVAC Package - 136" WB

Driver's side includes:

- (1) Aluminum 62"H x 84"L 4-shelf shelving unit
- (7) 12"D plastic bins with center divider & cross divider
- (1) Large bottle holder
- (1) Fixed Hook

Passenger's side includes:

- (1) Aluminum 62"H x 48"L 4-shelf shelving unit
- (1) 3 level refrigerant rack for bottles
- (10) Aluminum rattle-free dividers
- (1) 8" swivel hook (4" opening)

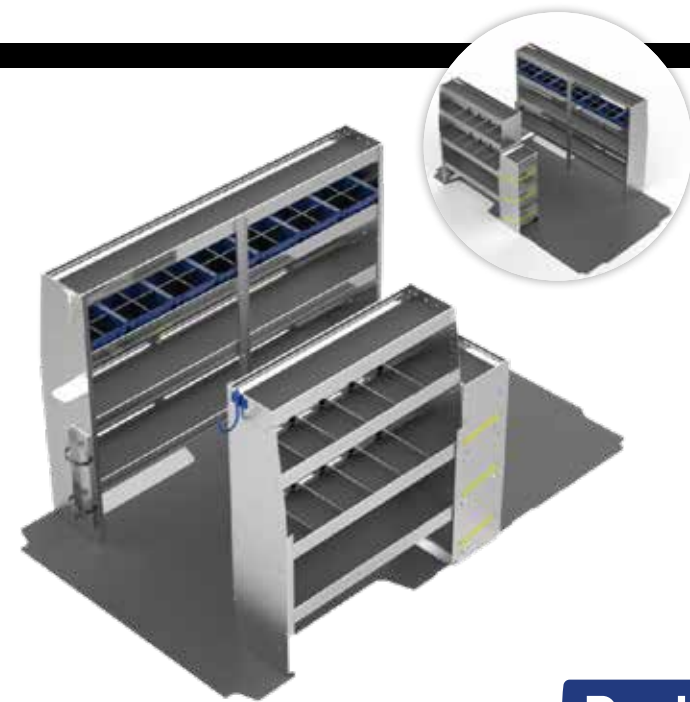

Packd

Partitions And Flooring Are Not Included In Shelving Packages

Description	Part#
HVAC Package, 136" WB	175D3HPX

Plumbing Package - 136" WB

Driver's side includes:

- (1) Aluminum 62"H x 84"L 4-shelf shelving unit
- (10) Aluminum rattle-free dividers
- (1) Large bottle holder
- (1) Fixed Hook

Passenger's side includes:

- (1) Aluminum 62"H x 48"L 5-shelf shelving unit
- (8) 12"D Plastic bins with center divider & cross divider
- (8) 14"D Plastic bins with center divider & cross divider
- (1) Large bottle holder
- (1) 8" swivel hook (4" opening)



Packd

Partitions And Flooring Are Not Included In Shelving Packages

Description	Part#
Plumbing Package, 136" WB	175D3PPX

HVAC Package - 159" WB

Driver's side includes:

- (1) Aluminum 62"H x 96"L 4-shelf shelving unit
- (8) 12"D plastic bins with center divider & cross divider
- (1) Large bottle holder
- (1) Fixed Hook

Passenger's side includes:

- (1) Aluminum 62"H x 60"L 4-shelf shelving unit
- (1) 3 level refrigerant rack for bottles
- (10) Aluminum rattle-free dividers
- (1) 8" swivel hook (4" opening)



Packd

Partitions And Flooring Are Not Included In Shelving Packages

Also Available for 118" WB
HVAC Package Part# 175D2HPX

Description	Part#
HVAC Package, 159" WB	175D5HPX

Plumbing Package - 159" WB

Driver's side includes:

- (1) Aluminum 62"H x 96"L 4-shelf shelving unit
- (10) Aluminum rattle-free dividers
- (1) Large bottle holder
- (1) Fixed Hook

Passenger's side includes:

- (1) Aluminum 62"H x 60"L 5-shelf shelving unit
- (10) 12"D Plastic bins with center divider & cross divider
- (10) 14"D Plastic bins with center divider & cross divider
- (1) Large bottle holder
- (1) 8" swivel hook (4" opening)

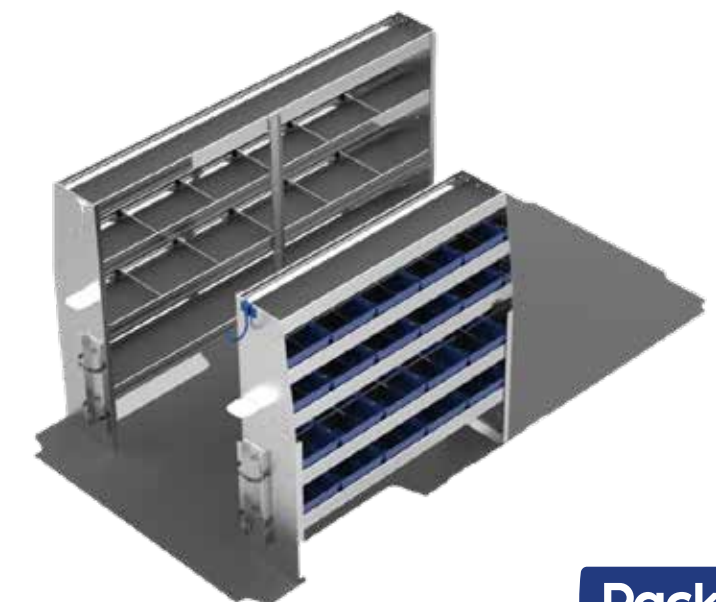

Packd

Partitions And Flooring Are Not Included In Shelving Packages

Also Available for 118" WB
Plumbing Package Part# 175D2PPX

Description	Part#
Plumbing Package, 159" WB	175D5PPX

Electrical Package - 136" WB

Driver's side includes:

- (1) Aluminum 62"H x 84"L 4-shelf shelving unit
- (1) 11"H x 33"L locking door cabinet
- (1) 11"H x 45"L locking door cabinet
- (7) 12"D Plastic bins with center divider & cross divider
- (1) Wire reel holder
- (1) Fixed Hook

Passenger's side includes:

- (1) Aluminum 62"H x 48"L 4-shelf shelving unit
- (10) Aluminum rattle-free dividers
- (1) 8" swivel hook (4" opening)



Packd

Partitions And Flooring Are Not Included In Shelving Packages

Description	Part#
Electrical Package, 136" WB	175D3EPX

Electrical Package - 159" WB

Driver's side includes:

- (1) Aluminum 62"H x 96"L 4-shelf shelving unit
- (2) 11"H x 45"L locking door cabinets
- (8) 12"D Plastic bins with center divider & cross divider
- (1) Wire reel holder
- (1) Fixed Hook

Passenger's side includes:

- (1) Aluminum 62"H x 60"L 4-shelf shelving unit
- (10) Aluminum rattle-free dividers
- (1) 8" swivel hook (4" opening)



Packd

Partitions And Flooring Are Not Included In Shelving Packages

Description	Part#
Electrical Package, 159" WB	175D5EPX

Also Available for 118" WB

Electrical Package Part# 175D2EPX

Delivery Package - 118" WB/136" WB

Driver's side includes:

- (1) 63"H x 72"L 2-shelf unit with folding shelves

Passenger's side includes:

- (1) 63"H x 48"L 2-shelf unit with folding shelves



Description	Part#
Delivery Package, 118" WB and 136" WB	176D3DP

Delivery Package - 159" WB

Driver's side includes:

- (1) 63"H x 60"L 2-shelf unit with folding shelves
- (1) 63"H x 48"L 2-shelf unit with folding shelves

Passenger's side includes:

- (1) 63"H x 48"L 2-shelf unit with folding shelves



Description	Part#
Delivery Package, 159" WB	176D5DP

- Folding shelves keep aisle clear when not in use
- Gas shock holds shelf in either up or down position - no latches or rattles
- Capacity is 250 lbs per shelving unit
- Shelves are 20" deep

DO YOU HAVE A FLEET OF 10+ VANS?

Contact us to learn about our fleet upfit solutions



Organized Time Saver

Access your most common items without even entering your vehicle.

Build a drawer system that works best for you

01. Start with a **Tool Drawer** for power tools and bags
02. Add **Parts Drawers** for hand tools and components
03. Finish with a **Top Tray** and crates or a **Worktop** surface



Our 6 Step Process

Start with Interior Finishing 01	Add a Safety Partition 02	Choose your Shelving Package 03
Add time-saving Interior Accessories 04	Select your Roof Equipment 05	Finish with Exterior Accessories 06

Tool Drawer

- Aluminum
- Weight capacity: 320 lbs
- Includes 3 large dividers
- Gray powder-coated drawer face
- 17"W x 45"L x 19.5"H
- Lockable



Description	Part#
Tool Drawer	DR10

Parts Drawer

- Aluminum
- Weight capacity: 150 lbs
- Drawer has paddle latch
- Gray powder-coated drawer face
- 12.5"W x 45"L x 7.5"H
- Lockable
- Mount individually, on top of tool drawer, or on top of other parts drawers



Description	Part#
Parts Drawer	DR11

Tool Drawer Top Tray

- Turn your tool drawer top into an additional storage area
- 17"W x 45"L x 4"H

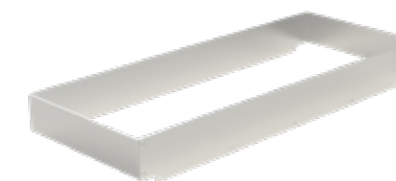

Description	Part#
Top Tray for Tool Drawer	TE10

Parts Drawer Top Tray

- Turn your parts drawer top into an additional storage area
- 12.5"W x 45"L x 4"H

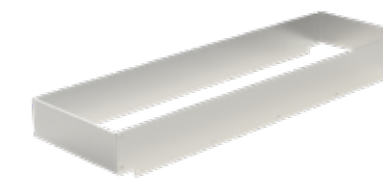

Description	Part#
Top Tray for Parts Drawer	TE11

Stackable Space Saving Storage

Mix and match to meet your needs



Add a Worktop to Your Drawer System

- 18"D x 48"W hardwood butcher block top
- Mounts to top of drawer system



Description	Part#
Drawer System Worktop	176XWT

Maximize your Productivity!

Bring all of your small parts in one trip

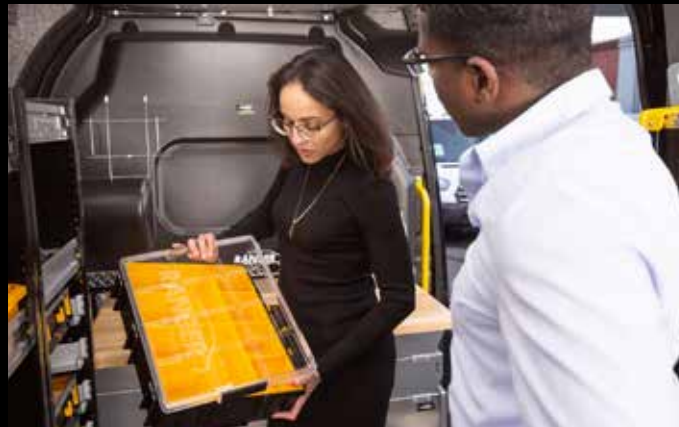

Incorporate time saving Parts Keepers into your upfit:

- 1) Add single Parts Keeper units onto your shelves
- 2) Mount a Parts Keeper cabinet at your side door for easy access



Be Efficient! Saving just 5 minutes per day will gain you 21 hours per year!

Single Parts Keeper

- Hangs underneath any shelf

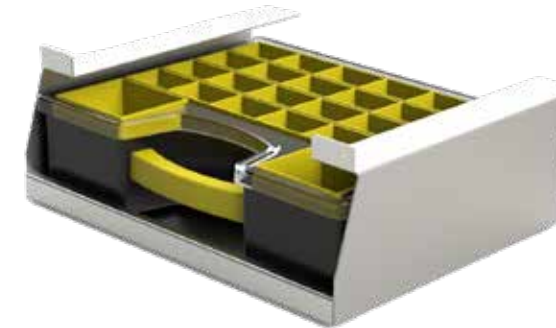

Description	Part#
Parts Keeper Case	PK-1

4 Pc. Parts Keeper Cabinet

- 1 Shelf
- Aluminum
- 17"W x 13.5"D x 24"H



Description	Part#
4 Pc. Parts Keeper	PK-4-1

5 Pc. Parts Keeper Cabinet

- 2 Shelves
- Aluminum
- 17"W x 13.5"D x 45"H

8 Pc. Parts Keeper Cabinet

- 1 Shelf
- Aluminum
- 17"W x 13.5"D x 45"H

8 Pc. Parts Keeper Cabinet

- 2 Shelves
- Aluminum
- 17"W x 13.5"D x 62"H



Description	Part#
5 Pc. Parts Keeper	PK-5-2



Description	Part#
8 Pc. Parts Keeper	PK-8-1



Description	Part#
8 Pc. Parts Keeper with 2 Shelves	PK-8-2

2-Drawer & 3-Drawer Cabinets:

- Latching drawers with ball bearing slides
- Includes key lock for security
- Cabinets can be individually mounted to shelves or stacked on floor
- 12.5"D x 18.5"W x 10.5"H

9-Drawer Cabinet:

- Rattle-free plastic drawers with dividers
- Includes built-in drawer catch
- 12.5"D x 17"W x 12"H



Contractor Approved

“The drawers are super smooth and I couldn't be happier with them. High quality item.”

Leslie N.

Locking Door



Description	Part#
45"W x 10"H Locking Door (5 hole spacing for 48"W shelving unit)	SD1045
45"W x 11.5"H Locking Door (6 hole spacing for 48"W shelving unit)	SD1145*
45"W x 13"H Locking Door (7 hole spacing for 48"W shelving unit)	SD1345

*Default size/shelf spacing

Dividers (Pack of 5)



Description	Part#
11" Aluminum Shelf Dividers	CDS-11
12" Aluminum Shelf Dividers	CDS-12
14" Aluminum Shelf Dividers	CDS-14

Bins



Description	Part#
11"D Plastic Bin	PBS-11
12"D Plastic Bin	PBS-12
14"D Plastic Bin	PBS-14

2-Drawer Cabinet



Description	Part#
2-Drawer Cabinet	876XX2DC

3-Drawer Cabinet



Description	Part#
3-Drawer Cabinet	876XX3DC

9-Drawer Cabinet

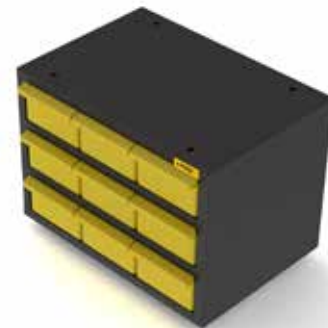

Description	Part#
9-Drawer Cabinet	876XX9DC

Moveable Hooks

- Use two Large Moveable Hooks to hang ladder from shelving
- Clips to shelving lip



Description	Part#
Small Moveable Hook	AC74
Large Moveable Hook	AC73

Swivel Hook

- Powder-coated blue finish



Description	Part#
Swivel Hook	AC72

Fixed Hook



Description	Part#
Fixed Hook (3" opening)	AC70
Large Fixed Hook (4" opening)	AC71

INTERIOR ACCESSORIES

INTERIOR ACCESSORIES

Cab Organizer Box



Description	Part#
Locking Aluminum Cab Box Organizer with Raise	876DXCB

Paper Holders



Description	Part#
Aluminum 3-Slot Paper Holder	AC10
Aluminum 5-Slot Paper Holder	AC14

First-Aid Kit



Description	Part#
First-Aid Kit With Holder	864XXFA

Triangle Kit



Description	Part#
Triangle Kit	876XXTK

Hard Hat Holder



Description	Part#
Hard Hat Holder	876XXHH

Grab Handle

- High grip surface
- Increase safety and efficiency



Description	Part#
Grab Handle	876XXGH

Small Bottle Holder

- For B and MC tanks



Description	Part#
Small Bottle Holder	RS86

Large Bottle Holder

- For nitrogen tanks



Description	Part#
Large Bottle Holder	RS88

Refrigerant Rack Two Level

- For refrigerant tanks
- Keeps tanks vertical



Description	Part#
Two Level Adjustable Bottle Holder	RS10

Refrigerant Rack Three Level

- For 30lb & 50lb refrigerant racks
- 13"W x 45"H



Description	Part#
Large Aluminum 3 Tier Refrigerant Rack	RS-3L-1

Refrigerant Rack Four Level

- For 30lb refrigerant tanks
- 10.5"W x 45"H

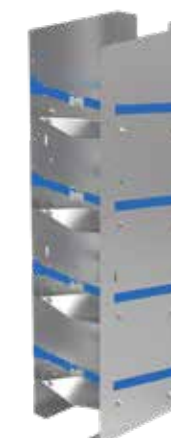

Description	Part#
Small Aluminum 4 Tier Refrigerant Rack	RS-4S

Refrigerant Rack Five Level

- For 30lb & 50lb refrigerant tanks
- 13"W x 62"H

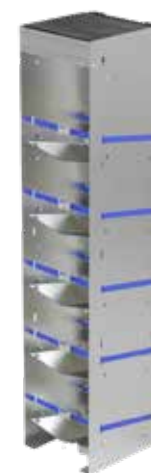

Description	Part#
Large Aluminum 5 Tier Refrigerant Rack	RS-5L-1

INTERIOR ACCESSORIES

INTERIOR ACCESSORIES

Side Dropdown Ladder Rack

Rear Dropdown Ladder Rack

Max Rack

- All aluminum construction
- Removable rotation bar included

Single Side Drop Down



Double Side Drop Down



Description	118"WB Part#	136"WB Part#	159"WB Part#	159"WB EXT Part#
Single Side MaxRack, holds (1) extension ladder (up to 32'L) or 10' stepladder	376D2SR	376D3SR	376D5SR	376D6SR
Double Side MaxRack, holds (2) extension ladders (up to 32'L) or 10' stepladders	376D2DR	376D3DR	376D5DR	376D6DR
Double Side MaxRack with 3rd Crossbar, holds (1) extension ladder (up to 32'L) and (1) 8' Stepladder	376D2DR3	376D3DR3	376D5DR3	376D6DR3
Optional Crossbow End Stops (add to Single Side MaxRack for additional roof storage capacity on Driver's Side)	376XXCES	376XXCES	376XXCES	376XXCES

Ergo Rack



- Aluminum and steel construction
- Removable rotation bar included



Single-Side Drop Down



Double-Side Drop Down

Description	Part#
Single Side ErgoRack, holds (1) extension ladder (up to 36'L) or 10' stepladder	374DXSR
Double Side ErgoRack, holds (2) extension ladders (up to 36'L) or 10' stepladders	374DXDR
Double Side ErgoRack with 3rd Crossbar, holds (1) extension ladder (up to 36'L) and (1) Stepladder (6' - 8'L)	374DXDR3

Access Stow



Double Access Stow



Single Access Stow

- Rust-free aluminum and stainless construction
- Fast, easy operation
- Ergonomic and safe rear deployment
- Works for extension ladders up to 32' or step ladders up to 10'

Single Access Stow



Double Access Stow

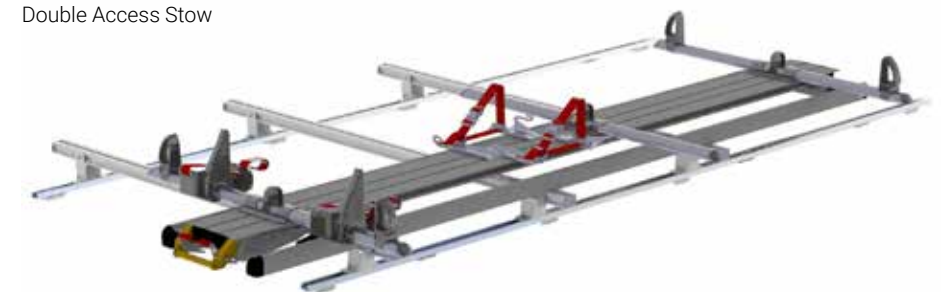

Description	Single Access Stow	Double Access Stow
118" WB Low Roof	376D2SS	376D2DS
136"WB Low Roof	376D3SS	376D3DS
136"WB High Roof	376D4SS	376D4DS
159"WB High Roof	376D5SS	376D5DS
159"WB Ext High Roof	376D6SS	376D6DS

Our 6 Step Process

Start with Interior Finishing 01	Add Safety and Security 02	Choose your Shelving Package 03
Add time-saving Interior Accessories 04	Select your Roof Equipment 05	Finish with Exterior Accessories 06

Roof Decks

- Heavy duty anodized aluminum construction
- Aerodynamically designed
- Includes rear roller
- Optional ratchet tie downs to secure any type of load



Model	Part#
118" WB Low Roof	376D2RD
136" WB High Roof	376D3RD
159" WB High Roof	376D5RD
159" WB Ext High Roof	376D6RD
Set of Two Ratchet Tie Downs	376XXRTD

Access Ladders



Bolt-on



Clamp-on

- Heavy duty extruded aluminum
- Contoured to fit ProMaster
- White bolt-on ladder recommended for cargo racks
- Anodized clamp-on ladder recommended for roof decks

Model	Bolt-on Part#	Clamp-on Part#
Low Roof	795DXALW	774DXALL
High Roof	795DXALW	774DXALH

Cargo Racks

- Rust-free aluminum construction
- Includes ladder stops & straps
- Optional rear roller to aid in loading and protect brake lights



*optional rear roller bar



Model	Part#
2 Bar Rack	395DX2B
3 Bar Rack	395DX3B
Rear Roller	395DXRR

Conduit Carrier

- 5" square rigid one piece design
- White powder-coated aluminum with black end caps
- Inside length of 10' 8"
- Lockable
- Add to any ladder rack



Description	Part#
Conduit Carrier	774XXCT

Ratchet Tie-Downs

- Recommended two per side
- Safely secure any type of load



Model	Part#
Set of 2 for Roof Decks	376XXRTD
Set of 2 for Cargo Racks	795XXRTH1S

Grip Step Running Boards

- 7" wide stepping surface
- Black powder coat aluminum
- Open tread design for maximum grip
- 98" passenger's board and 36" drivers board



Description	Part#
Running Boards (Driver's side and passenger's side set)	760DXRB

Grip Step Rear Step

- Black powder-coated aluminum
- 7" wide stepping surface
- High traction open tread design



Description	Part#
Grip Step Rear Step	760DXBAS

* Rear steps not compatible with a hitch

Max Step Rear Step

- Heavy-duty steel frame
- Anti-slip plastic treads
- Reflective strip

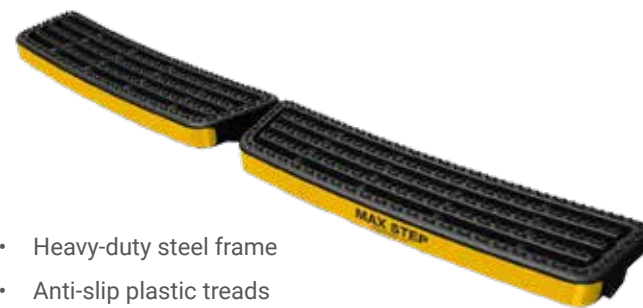

Description	Part#
Max Rear Step	776DXBAS

* Rear steps not compatible with a hitch

Tow Hitches

- Class III (500 lb tongue weight, 5000 lb trailer weight)
- 4-way flat & 7-way wiring systems

* WARNING: Requires a Digital Brake Controller to enable trailer brakes.

Description	Part#
Hitch – Class III Hitch for All Models	706DXTH
4-Way Flat Wiring Kit	506DX4TC
Duplex 7-way/4-way Wiring Kit*	506DX7TC
Digital Brake Controller	506XXTBC



Duplex 4-Way Flat & 7-Way Wiring



Digital Brake Controller

Windows

- OEM fit
- Light smoke tint



Description	Part#
Rear LH & RH	743DXRW
Driver's Side Forward	743D3DSFW
Sliding Door	743D3SDW
Porthole	732XXPW



Hasp Locks

- High security shielded hasps
- Solid steel "puck" style locks included

Slick Locks

- High security hasps use factory mounting points
- Solid steel "puck" style locks included
- Custom fit for drill-free installation

Description	Hasp Lock Part#
Hasp locks (set of 2)	758XXHL
Slick locks (set of 2)	788DXSL



Hasp Lock



Slick Lock

HVAC Tie-In System

- Engine-driven system designed for generally moderate climates
 - Achieve an indoor temperature approximate 12-15 degrees below the maximum outside temperature
 - Adds a high-capacity evaporator in the cargo area
 - Ties in to vehicle's existing OEM compressor and condenser
 - Connects into vehicle's existing coolant lines for heat function
- Application Example:**
- Art Transport
 - Mobile Showrooms



NOTE.
Products shown on this page are not available for onsite install

Description	Part#
Tie-In HVAC System	997XXTI

HVAC Extreme Climate System

- Engine-driven system designed for the most demanding HVAC requirements
 - Achieve an indoor temperature of up to 30 degrees below the maximum outdoor temperature
 - Adds a high-capacity evaporator in the cargo area
 - Adds a powerful auxiliary compressor in the engine compartment
 - Adds an additional condenser (either rooftop mount or underbody options)
 - Connects into vehicle's existing coolant lines for heat function
- Application Example:**
- Animal Transport
 - Mobile Labs



Description	Part#
HVAC Extreme Climate System	Call for details

Fuel-fired Heaters

- High-performance combustion heater for safe, reliable heat
 - Powered through the vehicles existing fuel tank
 - Gas and diesel options
 - Pair with our auxiliary battery/charging system for vehicle-off operation
 - Compact design mounts almost anywhere on the floor
 - Uses as little as 1 gallon of fuel per 22 hour period
 - Up to 7,000 BTU/h heat output
- Application Example:**
- Carpet Cleaners
 - Mobile Pressure-Washers



Description	Part#
Fuel-Fired Heater, gas engines, with Standard Controller	997XXGSC
Fuel-Fired Heater, gas engines, with Programmable Controller	997XXPSC
Fuel-Fired Heater, diesel engines, with Standard Controller	997XXDSC
Fuel-Fired Heater, diesel engines, with Programmable Controller	997XXPSC

Compact Power Inverters

- Pure Sine Wave – safe for electronics and lithium-ion chargers
- 1,200W - 2,000W options
- Perfect for occasional and light/medium loads
- Runs most basic hand tools, chargers, and small appliances
- Single GFCI outlet built into unit



NOTE.
Products shown on this page are not available for onsite install

Description	Part#
1,200W Pure Sine Wave Inverter with cabling & fuse	596XX1.2PI
Bluetooth Adaptor for 1,200W Inverter	596XXBD
Remote Switch for 1,200W Inverter	596XXRS
2,000W Pure Sine Wave Inverter with cabling & fuse	503XX2PI-HF
Remote Switch for 2,000W Inverter	503XXRS

Heavy Duty Power Inverter/Charger Systems

- Designed for daily use in industrial applications
- 3,000W - 10,000W options
- Perfect for utilities, mobile workstations, and high-surge loads
- Hardwire only - configure with multiple outlets and shore power charging
- Bluetooth-enabled plus remote monitoring options



*110V outlets and shore power inlet not included – call to configure

Description	Part#
3000W Pure Sine Wave Inverter/Charger* with cabling & fuse	596XX3PI
5000W Pure Sine Wave Inverter/Charger* with cabling & fuse	596XX5PI
Digital Remote Control Panel	596XXRC

Auxiliary Batteries

- Enables inverter operation with vehicle off
- Provides reserve power for high-surge loads
- 100AH-460AH battery bank options
- Isolated from OEM battery for reliable starts
- Automatically charged via vehicle alternator or optional shore power



Description	Part#
100AH AGM Deep-Cycle Battery with Isolator and Battery Box	503XX1AB-B
200AH AGM Deep-Cycle Battery with Isolator and Battery Box	503XX2AB-B
Battery Monitor – Bluetooth enabled	596XXBMS

Cantilever Series



- Most popular model
- 1300lb capacity
- Folds to allow rear door access while stowed
- 53"W x 60"L Load Area
- Built in cart stops

V2 Series

- 1100lb capacity
- Stores inside vehicle
- 47"W x 49"L Load Area
- Built in cart stops



NOTE.
Products shown on this page are not available for onsite install

Description	Part#	Description	Part#
All ProMasters (except 3500 Extended vans)	921DXCS	All ProMasters (except 3500 Extended vans) *	989DXV2
3500 Extended ProMaster *	921D6CS	3500 Extended ProMaster *	989D6V2

* Available on special order only

Don't see what you're looking for?

Contact us to design a custom build, we love a challenge!



Mobile Laboratory

Challenge: A manufacturer was looking to perform climate controlled hydraulic tool calibration onsite for their customers.



Incident Command

Challenge: A regional OEM was looking to manage agency communications and radio distribution at major emergency scenes.



Mobile Showroom

Challenge: A luxury stone & tile distributor was looking to grow their business by bringing their showroom to their clients.

118" WB

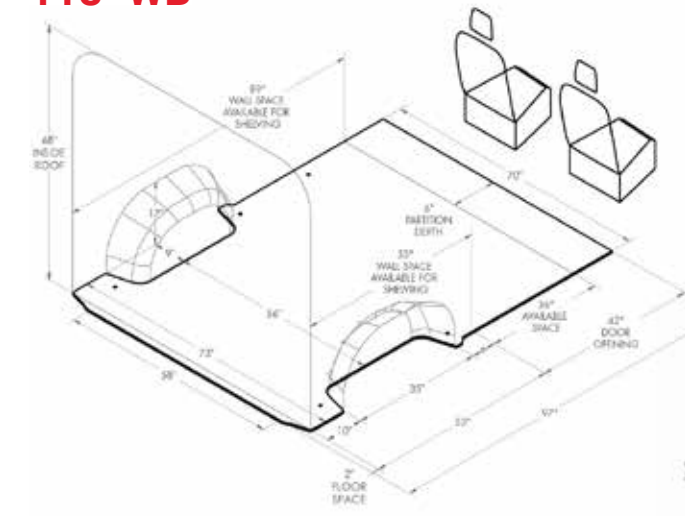

136" WB

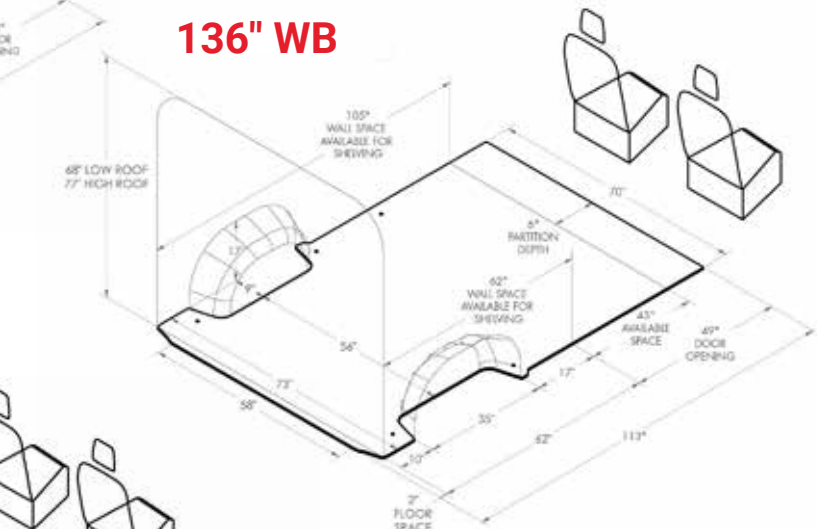

159" WB

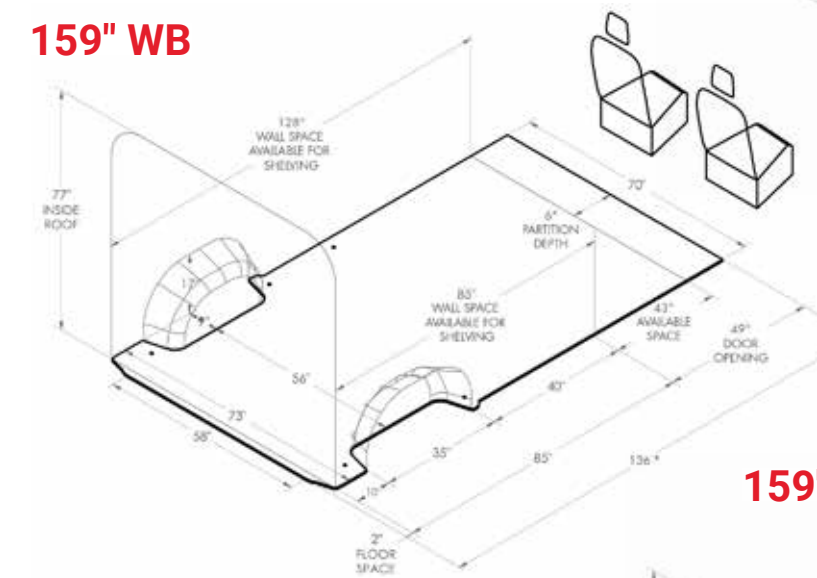

159" EXT WB

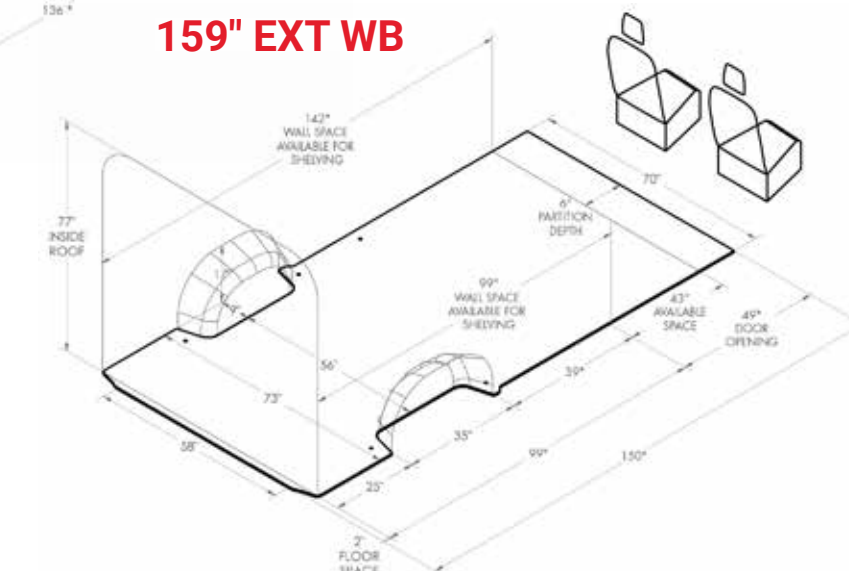

7500+

Vans Upfitted Per Year

Your ProMaster Customizing Starts Here.

Let Advantage Outfitters
make your van work ready!

95% Stock Orders Completed in
48 Hours or Less



Serving the tri-state region

New York · New Jersey · Connecticut · Pennsylvania

Contact Your RAM Dealer



WEST
255 West Street
South Hackensack,
NJ 07606

EAST
107 E. Hawthorne Ave.
Valley Stream,
NY 11580

sales@advantageoutfitters.com

866.925.4844

advantageoutfitters.com